

1998 - 1999



**Travel Trailer
& Fifth Wheel
Owner's Manual**

Welcome to Coachmen's growing family of happy RV owners. Hours of relaxation, adventure and enjoyment await you in your new Coachmen unit. Thousands of Coachmen RV owners have been enjoying their units for many years.

This Owner's Manual has been prepared to help you and your family enjoy your new Coachmen RV to its fullest by providing basic instructions for the operation and maintenance of its appliances, accessories and RV systems. Please read it carefully and follow the instructions. Also read and follow the instructions contained in the chassis, appliance and accessory manufacturers' instruction booklets provided as part of the "Coachmen Owner Information Guide."

If you have any questions regarding operation, maintenance or service, please contact your Coachmen dealer so he can assist you. Your satisfaction is of the utmost importance to your dealer and to Coachmen.

Operation and maintenance instructions regarding appliances in this manual were obtained from the manufacturer's booklets and are used with the permission of those various manufacturers. Coachmen Industries reserves the right to present edited portions of these materials.

Coachmen Industries, Inc. works year round to improve its product. As a result, all specifications, equipment and prices quoted are subject to change without notice or obligation to the consumer.

Coachmen offers a wide variety of recreational vehicle models and choices of standard and optional equipment; therefore, certain descriptions in this manual may not apply to your unit. Ask your authorized dealer, or see the current brochure for information on the availability of standard or optional equipment.

Thank you for selecting our product. The entire Coachmen Industries family strives to merit your confidence.

Join the International Coachmen Caravan

The International Coachmen Caravan is your owners' club. It is designed to help you get the most pleasure from owning a Coachmen recreational vehicle. With your membership you'll receive:

Membership Package: The first benefit a member receives is a complete Caravan Identification Package. It includes a membership card, Coachmen Caravan decals and unit numbers. These are all-important to identify you as a full-fledged Caravaner eligible for all other Caravan benefits.

Personalized Trip Routing Service: We'll tell you the best way to go. Let us plan the itinerary that leads to your fun and traveling pleasure.

Magazine Discounts: Save on a variety of America's popular subscriptions. The magazines about camping, traveling and the great outdoor world are especially right for you and your lifestyle—and so are the savings.

Caravan Trips: Hit the Caravan trail. It's the high road to adventure all year long. Interesting places and events are a big benefit of Caravan membership. There's so much to see and do when you're a member of the Caravan. The professional Caravan staff is constantly striving to develop outstanding tours and events. Traveling to special places with a Caravan of friends is a memorable experience that families can enjoy together.

Caravan Capers: Catch the news that features you. Capers is the quarterly magazine that brings you news about Caravan members and chapters across the continent, information about forthcoming trips and rallies, and a variety of timely articles about the wonderful world of Coachmen Caravan. Capers is the special edition that's right for you.

Pete's Market: Pete's Market is the Caravaner's mail-order store, and it's stocked with a vast array of distinctive items to make your RV adventures more fun. Special decals, patches, clothing, accessories, jewelry, and some featuring Pete the Dalmatian, our symbol—all reasonably priced with discounts for Caravan members.

Discount Film Processing: Capture those beautiful memories on film. And see the sights again when you take lots of pictures of your Caravan trips and other RV travels. Mail in your film to Caravan's special discount film processing center.

Campground Discount Program: We have campgrounds all over the U.S. and Canada that will give active Caravan members a camping discount. All you need to do is present your Caravan Membership Card

continued on back

Subsequent Owner Information

If you are the second or subsequent owner of this recreational vehicle, it is important that you notify Coachmen RV of your name, address, date of purchase and the Serial Number of your RV. This information is vital for Coachmen RV to maintain up-to-date records of current ownership. Complete the form below, clip it, and mail it to Coachmen RV Company. You also may be entitled to the remainder, if any, of the warranty coverage. Please contact your local Coachmen dealer to have the appropriate forms and inspections completed.

Date of Purchase _____ RV Serial No. _____

Name of Former Owner _____

Your Name _____

Address _____

City _____ State _____ Zip _____ Phone No. _____ / _____

International Coachmen Caravan Membership Application

Name _____

Type of Unit _____

Spouse's Name _____

Length of Unit _____

Occupation _____

Children's Name and Date of Birth

Address _____

1. _____

City _____

2. _____

State _____ Zip _____

3. _____

Phone (_____) _____ - _____

4. _____

Ham Call Letters _____

5. _____

Previous Caravan Member? Yes No

Referred by _____

International No. _____

1 Year \$18.00 2 Years \$30.00 3 Years \$43.00

Expires _____

Bill Me

at the check-in counter of those Campgrounds listed in the Campground Directory. Staying at about 10 campgrounds listed will make up for the cost of your yearly dues.

Campground Manual Discounts: Take the scenic route! It's fun—and it's easy—when you have your guidebook, available at a special price, for RV campgrounds.

Local, State and District Activities: Enjoy get-togethers and outings with other Caravanners throughout the year. In addition to International Caravan trips and rallies, you can enjoy your local, state and district Caravan Chapter activities too! There's always something exciting to plan and attend.

Annual International Caravan Rally: Come and share your good times with fellow Coachmen travelers.

Key Return: If you loose your key ring identified with a special key tag number and the keys are found and dropped in a mail box, they will be returned to you through your Caravan office.

Membership Drive Awards: There is an excellent awards program with many awards available for bringing your friends into the International

Coachmen Caravan as members. You can receive a lifetime membership, rally and trip discounts. Details and awards break down will be in your membership packet.

ICC Master Card: As you support the Caravan, you help yourself. Caravan MasterCard special benefits include; No annual fee, Low 16% A.P.R., 25-day grace period on purchases, Automatic common-carrier travel insurance of \$100,000 at no additional cost, Access to more than 23,000 CIRRUS network automated teller machines in more than 3,000 cities across the U.S. and Canada—fast cash—24 hours a day—every day—added recognition for the Caravan whenever your card is used.

VISA or Master Card Accepted: Membership Fees, Pete's Market, International Rally Fees, Coachmen Caravan Trip Fees.

Emergency Road Tow Service: You have available at a very low price an emergency road program that covers not only your RV, but your tow vehicle or vehicle being towed as well.

To join the Caravan, complete, clip and mail the Membership Application, to the International Coachmen Caravan, P.O. Box 30, Middlebury, IN 46540.

PLACE
STAMP
HERE



Subsequent Owner

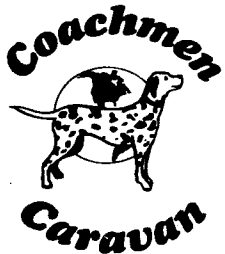

PLACE
STAMP
HERE

INTERNATIONAL COACHMEN CARAVAN
P.O. BOX 30
MIDDLEBURY, INDIANA 46540

New Membership

Table of Contents

APPLIANCE IDENTIFICATION FORM	48	POWER DISTRIBUTION CHART	22
APPLIANCES & ACCESSORIES	27	PRE-TRAVEL CHECK APPENDIX A:	37
Range, Range Hood, Oven	27	General Driving Checks	37
Microwave Oven	28	Other Driving Checks	37
Water Heater	28	REPORTING SAFETY DEFECTS	49
Furnace	29	RV MAINTENANCE	34
Refrigerator	30	SLIDE OUT OPERATION	17
Washer/Dryer	31	STORAGE	33
Roof Air Conditioner(s)	31	TOW VEHICLE SELECTION	9
AM/FM Radio & Cassette Player	32	Engine Size	9
TV Antenna/Cable System	32	Hitch Selection	9
Television	32	TOWING HOOK-UP	11
Cable TV & Phone Jack	32	Travel Trailer	11
BASIC UTILITY SYSTEMS	20	Coupler	11
Electrical System	20	Front Jack	12
Fresh Water System	22	Safety Chains/Electrical Connections	12
Drainage/Sewer System	23	Breakaway Switch	12
LP Gas System	24	Hitch Ball height	12
CAMPING	16	Fifth Wheel	12
DRIVING	15	Hitching	12
ELECTRICAL SPECIFICATIONS	48	Electrical Connection	12
Pigtail Wiring Diagram	48	Ground Clearance	12
Light Bulbs	48	TRAILER/FIFTH WHEEL BRAKES APPENDIX C:	40
FIRE SAFETY	34	How Your Brakes Work	40
Smoke Detector	34	Brake Synchronization	40
Emergency Exits	34	Brake Adjustment	40
IMPORTANT SAFETY REGULATIONS	8	TRAVEL PREPARATION CHECK LIST	
INTRODUCTION	9	APPENDIX B:	39
Licenses	9	TRAVEL PREPARATIONS	10
Insurance	9	General Driving Checks	10
LIVING AREA	18	Important Documents	10
Air Quality	18	Courtesy	10
Condensation	18	Tourist Information	10
LOADING	13	TRAVEL RECORD	45
Weight Determinations	13	TROUBLE SHOOTING GUIDE APPENDIX D:	41-44
Federal Sticker	13	VISITING CANADA OR MEXICO	11
Definitions	13	WARRANTY	6-7
Weighing: Travel Trailer/Fifth Wheel	14	WINTERIZATION	33
Tips on Reloading	15		
MAINTENANCE RECORD	46		
MAINTENANCE SCHEDULE	47		

NEW RECREATIONAL VEHICLE LIMITED WARRANTY



Scope

The Coachmen "Buckstopper" Limited Warranty applies to new vehicles sold by an authorized Coachmen RV dealer for one year from either the original retail purchase date or the date the vehicle was first put in to use, or the first 15,000 miles of total use, whichever occurs first. A signed warranty registration form must be received by Coachmen to activate your warranty. This warranty applies only to the original owner; however, it may be transferred to subsequent owners during the warranty period with proper application and a \$45 processing fee.

Coverage

During the warranty period, Coachmen Recreational Vehicle Company will make any repairs to both the "recreational vehicle" and "automotive" portions of the product as described below, which might become necessary due to defects in original material or workmanship. We will repair or replace any defective part at no cost to you. Because of design changes, we may substitute parts or components of substantially equal quality.

"Recreational vehicle" within this limited warranty means all portions of the product which are used or primarily maintained as a mobile dwelling, and excludes any components that are typically found in an automobile. These "RV" portions, also referred to as "living facilities", include but are not limited to: the plumbing system and fixtures, LP system, appliances, roof air conditioner(s) and RV furnace (and related ducting), electrical systems unrelated to the propulsion of the vehicle, RV entrance door, exterior compartments, and windows other than the windshield and driver and passenger window.

"Automotive" within this limited warranty means those portions of a motorized product (if applicable) which were installed by Coachmen, and which may include: the cockpit driver and passenger door, windshield and driver and passenger window, windshield wipers, dash air conditioner and heater, dash gauges and controls, exterior automotive lights and mirrors.

Defects or damage to interior and exterior surfaces, trim, upholstery and other appearance items that may occur prior to delivery usually are corrected during the inspection process at the manufacturing facility and the dealership. If you have any concern over any such item when you take delivery of your vehicle, please notify your dealer without delay.

Exclusions

The "Buckstopper" Limited Warranty applies only to materials and components originally built or installed by Coachmen. It does not cover the automotive chassis' components or tires; batteries, generators or televisions which are warranted separately by their manufacturers. It also does not cover damage caused by lack of proper use, improper operation or maintenance in accordance with the Owner's Manual, overloading, abuse, collision, environmental damage, alterations or improper repairs, service call charges, corrosion, cosmetic flaws, or normal deterioration/wear of fabrics and carpeting. Also excluded: any product not used for its customary purpose; any product not registered and normally used in the United States or Canada; use of the vehicle for rental, and any promises made by any person beyond those stated in this Warranty.

To Obtain Service

For warranty service, simply contact an authorized Coachmen Dealer or Service Center for an appointment or consultation, then take the vehicle (at your expense) to the servicing facility.

Limitation of Implied Warranties:

IMPLIED WARRANTIES, INCLUDING THE IMPLIED WARRANTY OF MERCHANTABILITY AND IMPLIED WARRANTY OF FITNESS FOR A PARTICULAR PURPOSE, ARE LIMITED IN DURATION TO THE TERM OF THIS LIMITED WARRANTY. There is no warranty of any nature made by Warrantor beyond that contained in this Warranty. No person has authority to enlarge, amend or modify this Warranty. The dealer is not the Warrantor's agent but an independent entity. Warrantor is not responsible for any undertaking, representation or warranty made by any dealer or other person beyond those expressly set forth in this Warranty. Some states do not allow limitations on how long an implied warranty lasts, so the above limitation may not apply to you.

Disclaimer of Consequential and Incidental Damages:

THE ORIGINAL PURCHASER OF THE VEHICLE AND ANY PERSON WHOM THE VEHICLE IS TRANSFERRED, AND ANY PERSON WHO IS AN INTENDED OR UNINTENDED USER OR BENEFICIARY OF THE VEHICLE SHALL NOT BE ENTITLED TO RECOVER FROM WARRANTOR ANY CONSEQUENTIAL OR INCIDENTAL DAMAGES RESULTING FROM ANY DEFECT IN THE VEHICLE, including, but not limited to, transporting the vehicle for service, lodging, meals, loss of use of the product, legal expenses, loss or damage to personal property, inconvenience or loss of income. Some states do not allow exclusion or limitation of consequential or incidental damages, so the above exclusions may not apply to you.

Legal Remedies

ANY ACTION TO ENFORCE THIS WARRANTY SHALL NOT BE COMMENCED MORE THAN ONE (1) YEAR AFTER THE EXPIRATION OF THIS WARRANTY. This warranty gives you specific legal rights, and you may have other rights which vary from state to state.

It is the intent of Coachmen RV Company to satisfy our valued customers. If you have a problem obtaining satisfactory and timely warranty service that may substantially impair the use, value or safety of your Coachmen product, please call us on our toll free line (1-800-453-6064) so that we may attempt to resolve your concerns.



OUR WARRANTY

GENERAL—Your new Coachmen is backed by our position as an industry leader, achieved through decades of experience in producing RV's noted for their quality and dependability. Our warranty demonstrates our confidence in our products and is a commitment to customers' continued satisfaction.

Every effort has been made to provide you with a safe, dependable recreational vehicle. Your Coachmen complies with applicable federal and state regulations and the requirements of ANSI A119.2, the nationally recognized "Standard for Recreational Vehicles—Installation of Plumbing, Heating and Electrical systems." The Recreation Vehicle Industry Association (RVIA) periodically inspects our production and assists in maintaining strict compliance with installation and safety standards for those systems. Similar periodic inspections of the systems are made by representatives of various states. You, the owner, must also perform periodic inspections of the systems and provide a program of preventive maintenance as described in the Owner's Manual and instruction booklets.

WARRANTY SERVICE—We recommend that warranty service be performed by the authorized dealer from whom you purchased your Coachmen because of the dealer's continued and personal interest in your satisfaction. But if you are traveling or in the event that you move, service under the warranty will be performed by any authorized Coachmen dealer. Whenever possible, make an appointment to avoid unnecessary delays. Non-emergency repairs can be done at a later date.

Always Carry Your Owner Registration Card, which must be presented to obtain warranty service. The card is proof of purchase and provides the date of retail sale, which are necessary to determine warrantability. If you cannot locate an authorized Coachmen dealer, contact Coachmen Customer Service, (219) 825-7000 or (800) 453-6064.

WARRANTY PERIOD—The warranty period is for 12 months or the first 15,000 miles total, whichever comes first. It begins on the date your new recreational vehicle is purchased, or the first inservice date, whichever is first.

WHAT IS COVERED—The Manufacturer warrants to owners that an authorized Coachmen dealer will make repairs made necessary by defects in material or workmanship during the warranty period. Such repairs will be made without charge for parts and labor to the owner.

WHAT IS NOT COVERED—Our warranty does not cover the tires, batteries or optional TVs and generators, repairs or adjustments required because of neglect, accident, misuse, failure to follow service and use instructions, normal wear and/or exposure, unauthorized repairs or unauthorized modifications to any part of the systems or body that might cause reduced performance or dealer installed options.

Your new Coachmen is designed as a temporary living quarters for recreational camping, travel or seasonal use and not as a permanent dwelling place. Usage as a permanent accommodation is a breach of warranty and we are not liable for any damage that results because of such misuse.

Coachmen does not assume responsibility for loss of use of the recreational vehicle, loss of time, inconvenience or expenses due to equipment failures (refer to the warranty statement for other exclusions and limitations).

OTHER WARRANTIES—Be certain to complete and submit to the appropriate manufacturers the warranty forms for tires, batteries and optional TVs and generators, which are not covered by our warranty. If service or parts are required for these products, please refer to the furnished list of factory-authorized service centers. If the list is not available, write or call the manufacturer concerned to obtain the location of the nearest authorized service center.

CUSTOMER SERVICE—Owner satisfaction and goodwill are of primary concern to Coachmen. We recognize that our continued success as a leading manufacturer of recreational vehicles depends upon your complete confidence in our products and service. A pleasant and effective relationship through our dealers is as important as maintaining the technical excellence of our product. Your authorized dealer will assist you in providing service, maintenance, selection of options and instructions concerning the operation of your recreational vehicle.

Occasionally, a warranty or service matter may not be handled to your satisfaction. Often it is the result of a misunderstanding and can be resolved at the dealer level. Discuss the situation with the dealership management. If you cannot find satisfaction at the dealer level, we invite you to contact our Customer Service Department, where we will make every effort possible to find an agreeable solution. In most instances, we will eventually refer you back to the local dealer with our recommendations.

Write or telephone: Customer Service Department, P.O. Box 1000, Middlebury, IN 46540, (219) 825-7000 or (800) 453-6064.

IMPORTANT SAFETY REGULATIONS

... please read carefully.

LP GAS SYSTEMS AND APPLIANCES

Coachmen Industries is required to furnish the following consumer information as provided by the National Fire Prevention Association and the American National Standards Institute. The information and warnings found here may also be found in other sections of this Owner's Manual. Please see sections titled "LP Gas System" and "Appliances" for other safety and operating information.

WARNING!

LP gas containers shall not be placed or stored inside the vehicle. LP gas containers are equipped with safety devices which relieve excessive pressure by discharging gas to the atmosphere.

WARNING!

It is not safe to use cooking appliances for comfort heating. Cooking appliances need fresh air for safe operation. Before operation:

1. Open overhead vent or turn on exhaust fan.
2. Open window.

A warning label has been located in the cooking area to remind you to provide an adequate supply of fresh air for combustion. Unlike homes, the amount of oxygen supply is limited due to the size of the recreational vehicle, and proper ventilation when using the cooking appliance(s) will avoid dangers of asphyxiation. It is especially important that cooking appliances not be used for comfort heating as the danger of asphyxiation is greater when the appliance is used for long periods of time.

WARNING!

Portable fuel-burning equipment, including wood and charcoal grills and stoves, shall not be used inside this recreational vehicle. The use of this

equipment inside the recreational vehicle may cause fires or asphyxiation.

WARNING!

Do not bring or store LP gas containers, gasoline, or other flammable liquids inside the vehicle because a fire or explosion may result.

A warning label has been located near the LP gas container. This label reads: DO NOT FILL CONTAINER(S) TO MORE THAN 80 PERCENT OF CAPACITY.

Overfilling the LP gas container can result in uncontrolled gas flow which can cause fire or explosion. A properly filled container will contain approximately 80 percent of its volume as liquid LP gas.

The following label has been placed in the vehicle near the range area:

IF YOU SMELL GAS:

1. Extinguish any open flames, pilot lights and all smoking materials.
2. Do not touch electrical switches.
3. Shut off the gas supply at the tank valve(s) or gas supply connection.
4. Open doors and other ventilating openings.
5. Leave the area until odor clears.
6. Have the gas system checked and leakage source corrected before using again.

LP gas regulators must always be installed with the diaphragm vent facing downward. Regulators that are not in compartments have been equipped with a protective cover. Make sure that regulator vent faces downward and the cover is kept in place to minimize vent blockage which could result in excessive gas pressure causing fire or explosion.

INTRODUCTION

Congratulations on the purchase of your new Coachmen RV. We sincerely thank you for choosing our product. To help you enjoy it, you'll find in this Owner's Manual many useful tips for camping trips as well as basic operation and maintenance information for your RV's systems and appliances.

TRY A SHORT TRIP FIRST. The experience you will gain from this will help make your future RVing more enjoyable.

To complement the standard and optional equipment you've chosen for your unit, there are many other accessories available. You may wish to use your unit several times before you invest in these accessories. What may be a necessity for one RVer could prove to be of no value to you. Remember, your dealer is always ready to help and advise you.

We go into great detail in this manual and for good reason. If you are a first-timer, we want you to learn to operate your RV correctly, to be able to use its components, appliances and any optional equipment in the most efficient manner.

At first glance, you may be overwhelmed by all the detail. But after you've used your new RV a couple of times, you'll be able to perform all the checks, start-ups and systems in much less time than it takes to read our instructions.

If you're a veteran RV owner, you know that things change and a quick review of this manual will bring you up to date on what's new.

So read on. Happy camping!

Note: *Because of the variety of models we offer, your RV may not have all of the components illustrated or described in this Owner's Manual. Ask your dealer for details concerning the specifics of your unit.*

LICENSES

Vehicle licensing laws vary from state-to-state. Check with your state license bureau or the nearest licensing branch office for the requirements of your state. Be sure to renew your driver's license if it has expired or will expire during your trip.

INSURANCE

Personal liability, property damage, collision and theft of contents may be features of your automobile insurance policy that apply to your RV. Talk to your insurance agent about the details of your coverage. Always carry your insurance policy and/or card with you when you travel.

TOW VEHICLE SELECTION

If you plan to tow your RV with an automobile or truck you already own, you might wish to upgrade your vehicle by adding heavier-duty shocks, heavier-ply tires,

larger battery, larger alternator, etc. Contact your tow vehicle dealer to find out your vehicle's towing capacity. If you plan to purchase a new tow vehicle, be certain to tell your dealer the size and type of RV the vehicle will be towing. Some automotive manufacturers publish brochures that discuss towing considerations. Ask your Coachmen dealer how to obtain a copy of this information.

To operate the electric brakes installed on your Coachmen RV, a brake control system **must** be installed in your tow vehicle. To make your trips more enjoyable, you might wish to add the following options to your tow vehicle: Air conditioning, automatic transmission, auxiliary transmission cooler, power brakes and power steering.

ENGINE SIZE

The engine must have enough horsepower to handle the tow vehicle, passengers, the RV unit and all of its cargo. Most automotive manufacturers offer a trailer towing package that usually includes the following: larger alternator and battery, heavier-ply tires, sideview mirrors, heavier electrical wiring and larger engine and transmission cooling systems. Consult your tow vehicle's owner's manual for recommendations.

Note: *Use of heavier suspension components (springs, shocks, axles) or heavier-ply tires does not increase the weight ratings printed on the tow vehicle's "certification" plate. The Gross Axle Weight Rating (GAWR) of each axle is determined by the axle system components with the lowest weight-carrying capacity. To avoid overloading your vehicle, check the Gross Vehicle Weight Rating (GVWR) and the GAWR.*

HITCH SELECTION

Hitch selection is important because it affects the towing and handling characteristics of your RV. Ask your Coachmen dealer about the proper class and type of hitch for your unit. Sway-control devices are available to reduce sway caused by crosswinds, other vehicles passing you or the RV tires dropping onto the shoulder of the road. You may also want to discuss this option with your dealer.

TRAVEL TRAILER

The travel trailer coupler fits a ball hitch. A weight-distributing (load-equalizing/leveling) hitch may be recommended for your unit. This type of hitch helps keep both the tow vehicle and the RV level by distributing part of the hitch weight forward to the tow vehicle's front axle and back to the trailer's axle(s).

Consult your Authorized Coachmen dealer for the hitch weight. Be certain your tow vehicle can carry the hitch weight. The required hitch ball diameter is stamped on the trailer coupler. Read the information supplied by the hitch manufacturer to achieve the best possible performance.

HITCH TYPES

STANDARD

Class	Type	Max. G.T.W.	Max T.W.
I	Weight Carrying	2000 lbs	200lbs
II	Weight Carrying	3500 lbs	300 lbs
III	Weight Carrying	5000 lbs	500 lbs
IV	Weight Distributing	10000 lbs	1000 lbs
V	Weight Distributing	14000 lbs	1700 lbs

(G.T.W.=Gross Trailer Wt. T.W.=Tongue Wt.)

Note: Carrying capacities may vary by hitch manufacturer. The above chart is to be used as a guide only. Please consult the hitch manufacturer for more information concerning your specific needs.

FIFTH WHEEL

The fifth wheel coupler fits a pin-type connection. The fifth wheel can be towed only by a pickup truck. Be sure the truck can carry the hitch weight of your Coachmen RV. The hitch weight for your Coachmen RV is listed in the sales brochure.

Fifth wheel hitch assemblies come in varying total weight and pin weight capacities. Please consult a local hitch supplier or the manufacturer for further information.

TRAVEL PREPARATIONS

It's always a good idea to **plan** your trips. Make arrangements for someone to check your house periodically while you're on your trip. Stop mail and newspaper delivery. If you intend to be away for more than two weeks, request police surveillance for your house. Carry an extra set of vehicle and house keys with you on a separate key ring.

Fill your fresh-water tank before leaving. When traveling in winter, however, don't fill the water tank until the interior of your unit is thoroughly warmed or until you reach your destination.

Decide on the various items of equipment, clothing, food and other supplies you'll need for the length and destination of your trip.

Each moment you spend loading your RV is time you lose from the length of your stay. To reduce loading time, stock your RV with a supply of plastic or paper dinnerware, stainless steel or plastic flatware, pots, pans, towels and bedding. Try to use paper, plastic and aluminum whenever possible. They are lighter and less likely to break when the vehicle is moving. If you are planning an extended trip, pack only enough food for two or three days; you can replenish your supply along the way. Plan meals so that fresh or refrigerated items are used before they spoil. Keep a basic supply of seasonings (sugar, salt, pepper, spices) in your RV. See APPENDIX B: TRAVEL PREPARATION CHECKLIST for more tips on what to pack for your trip.

GENERAL DRIVING CHECKS

For your safety, make certain that the following items have been checked and rechecked before you take your RV on the road. Be sure to read APPENDIX A: PRE-TRAVEL CHECK for additional driving checks.

All jacks and levelers—Must be raised as far as possible.

Lights—The following lights should be tested on both the RV and the tow vehicle: brake lights, warning lights, flashers, clearance lights, taillights and tow vehicle headlights.

Rearview mirrors—Adjust all rearview mirrors so that the driver can see the right and left side of the unit.

Pigtail—The pigtail should be connected properly to the tow vehicle's electrical harness.

Hitch coupler/pinbox—Inspect the hitch coupler or pinbox to be sure they have not loosened.

IMPORTANT DOCUMENTS

Always carry your vehicle registration, insurance policy card(s) and owner warranty registration card. If you are borrowing a vehicle, it is best to have with you a notarized letter of approval authorizing you to be in possession of the vehicle.

COURTESY

Common courtesy will help make your stay more pleasant. Campsites often are close together and loud noises may disturb neighboring campers. Follow the posted rules of the campsite. Open fires might not be permitted. If you are permitted to build a campfire, clear the area of all flammable materials; never leave a campfire unattended, and always make certain the embers are completely extinguished before leaving the campfire or before going to sleep.

TOURIST INFORMATION

Obtain current road maps and tourist information for each state you'll visit or drive through. You also may want to purchase a tourist guide book and/or a campground directory.

If you will be visiting federally-operated national parks, monuments and recreation facilities, you might find the Golden Age Passport and/or the Golden Eagle Passport useful. These passports can help families cut expenses at areas where fees are involved.

GOLDEN AGE PASSPORT is a free lifetime pass for persons age 62 and over. It covers all admission fees and includes a 50 percent discount on usage fees (except fees charged by privately operated concessions). This passport is available only at park service offices and at parks where entrance fees are charged. It cannot be obtained through the mail or at post offices. To obtain the Golden Age Passport, you will need proof of age, such as a driver's license. (Medicare cards are not accepted as proof of age.) If you do not have adequate proof of your age, be prepared to sign an affidavit swearing that you are at least 62 years of age.

GOLDEN EAGLE PASSPORT is designed for persons who plan to visit in a single year several parks or federally-operated facilities. It covers all admission charges, but does not cover usage fees. It is good only during the calendar year in which it is issued. It may be purchased in person or through the mail from the National Park Service Headquarters, department of the Interior, Washington, D.C. 20240; at regional National Park Service offices, or at similar facilities where entrance fees are charged.

Both Golden Age and Golden Eagle Passports cover admission fees for passengers accompanying the permit holder. Where entry to the recreation facility is not by private vehicle, such passport covers only the permit holder and the permit holder's immediate family.

VISITING CANADA OR MEXICO

The information in this section is general and is subject to change by the Canadian or Mexican government. For specific information, including rules for re-entering the U.S., as well as points of interest and campsites, contact the consulate nearest the point at which you plan to enter the country.

Passports or visas are not required for entry into Canada or Mexico. You must, however, carry your birth certificate, voter registration card, baptismal certificate or similar proof of identity when entering one of these countries. Naturalized U.S. citizens should carry their naturalization papers or other proof of citizenship. Persons under 18 years of age should carry a notarized letter from their parents or guardians giving them permission to travel in Canada or Mexico.

No special driver's license or permit is necessary in either country; but, renew your license if it has expired, or will expire during the trip. Proof of vehicle ownership is required at the border. If you are using some else's unit, you should have a notarized letter authorizing its use.

Note: Driver's license may not be considered as a valid identification.

MEXICO

A tourist card is necessary for visiting in Mexico if you will be staying more than 72 hours or travel more than 40 miles from the border. Cards can be obtained at the port of entry or from a Mexican consulate.

VEHICLES

Mexico requires a vehicle permit for every self-propelled vehicle. The permit can be obtained only from Mexican Auduana (customs) offices upon presentation of tourist card, vehicle registration and title or notarized statement from owner. Your insurance policy is **not** valid in Mexico. Temporary insurance must be purchased from Mexican companies (usually offices are located near the border).

CB RADIO

Mexico currently prohibits the use of CB radios.

HUNTING AND FISHING

Hunting and fishing laws in Mexico are extremely complicated. To request information, contact:

Secretaria de Comunicaciones
Estados Unidos Mexicanos
Mexico DF

DOGS AND CATS

Mexico requires a certificate signed by a licensed veterinarian. The certificate should describe the pet and

show that the pet has been vaccinated for rabies within the past six months. A fee is charged for the required verification of the certificate by a Mexican consulate.

CANADA

VEHICLES

Canada requires a Canadian Non-Residential Inter-provincial Motor Vehicle Liability Insurance card, which is available only from U.S. agents. All provinces in Canada require evidence of financial responsibility if visitors are involved in an accident. Limits vary from province to province. Contact your insurance agent for details.

CB RADIO

CB radio operation in Canada requires a temporary license. To obtain such a license, write to:

Regional Director
Telecommunications Regulation Branch
Department of Communications
20th Floor
2085 Union Avenue
Montreal, Quebec H3A 2C3
Canada

HUNTING AND FISHING

Revolvers, pistols and fully-automatic firearms are prohibited in Canada. Each province has its own laws and licensing requirements. You must provide a written description and the serial number of each gun at the border. A license must be obtained from the province in which you intend to hunt or fish. Further information can be obtained by writing to the Department of Lands and Forests, Wildlife Branch, in the province you intend to visit.

DOGS AND CATS

Canada requires a certificate signed by a licensed veterinarian in the U.S. or Canada stating that your dog has been vaccinated for rabies within the past 12 months. The certificate must contain a description of the dog and date of vaccination. Puppies under three months need no certificate. There is no restriction on the entry of healthy cats.

TOWING HOOK-UP

TRAVEL TRAILER

COUPLER

Turn the front jack handle clockwise (or activate your power jack) and raise the coupler above the hitch ball. Position the tow vehicle so that the ball is directly under the coupler. Lift the coupler lever up as far as possible. Turn the front jack handle counterclockwise (or activate your powerjack) and lower the coupler onto the ball. Secure the connection by pushing the coupler lever down until the latch shoulders rest on the top surface of the coupler.

For theft protection, you may wish to purchase a locking device that inserts through the coupler lever and the bracket holes.

FRONT JACK

Turn the crank counterclockwise until the dolly wheel/jack foot is off the ground. Remove the wheel or foot and store it. Continue turning the crank until the front jack is as high as possible; this will prevent it from hitting the ground during travel. If you have a power front jack, activate the switch and fully retract the jack. Depending on the model of your power jack, you may have to remove the switch cover before activating the switch; be sure to replace the switch cover after use.

SAFETY CHAINS/ELECTRICAL CONNECTIONS

Cross the safety chains under the "A" frame and attach them to the tow vehicle's hitch platform. Plug the pigtail into the tow vehicle's electrical harness. Leave enough slack in the chains and the pigtail to allow the unit to turn freely. Safety chains and pigtails should **not** touch the ground. For your convenience a pigtail wiring diagram is contained on page 48 of this manual.

BREAKAWAY SWITCH

The breakaway switch is a safety device that will automatically activate your RV's electric brakes if your RV unit accidentally separates from the hitch. Attach the switch-activating cable to the tow vehicle bumper or to the tow bar portion of the hitch platform. Do not loop the cable around the hitch ball. Adjust the cable length so that it pulls the pin out of the switch before the coupler drops onto the safety chains. Be sure to allow enough slack so that both vehicles turn freely without pulling the pin from the breakaway switch.

Lubricate the pin periodically to ensure good separation. Each time before using your trailer, make certain that the pin is securely in place.

Do not use the breakaway switch as a parking brake; it is intended for emergency use only.

Note: *The tow vehicle battery will not supply power to your unit's brakes if a separation occurs. If the pigtail also disconnects, the unit's brakes will not work unless an RV battery has been installed. Keep batteries charged at all times to ensure safe operation.*

HITCH BALL HEIGHT

When the loaded trailer is hitched to the tow vehicle, check the ball height. This can be determined by measuring the distance from the top of the curved portion of the coupler to the ground. Adjust the equalizing bars of the hitch assembly so that the tow vehicle and the trailer are essentially level.

A high hitch will transfer weight behind the axle(s) and cause the unit to fishtail. A low hitch will transfer additional weight to the hitch. Refer to the hitch manufacturer's instructions to adjust the weight distributing hitch to the proper height. If you need further assistance, contact your Coachmen dealer.

FIFTH WHEEL

HITCHING

There are several types of fifth wheel hitches. Although the one described here is typical, have your Coachmen dealer demonstrate and explain the proper hitching and unhitching procedure for your unit's hitch.

1. Lower or remove the tailgate of the pickup truck.
2. Release the hitch plate jaws by pulling the handle until a snap is heard.

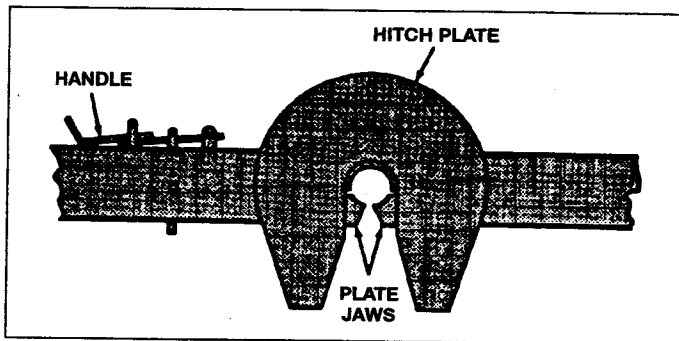

FIFTH WHEEL PLATE (TYPICAL)

3. Back the truck up until the pin is caught by the plate jaws.
4. Once connected, activate your electric jacks or turn the jack crank counterclockwise to raise the jacks as far as possible.
5. Remove the pin in each jack; raise the adjustable part of the jack as far as possible and reinsert the pin to hold the jack in position.

ELECTRICAL CONNECTION

Plug the pigtail into the electrical harness of the truck. Be sure there is enough slack to allow the vehicle to turn without disconnecting the pigtail.

GROUND CLEARANCE

When the loaded unit is connected to the tow vehicle, check the ground clearance. If the front of the unit is too high, weight will be transferred behind the axle(s). This could cause the unit to fishtail. If the front of the unit is too low, additional weight will be transferred to the truck.

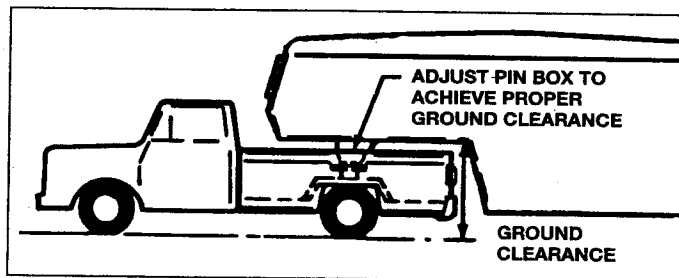

FIFTH WHEEL GROUND CLEARANCE

For proper height, adjust the pinbox by removing the bolts on each side. Raise or lower the box until the holes are aligned, and then reinsert and tighten the bolts.

LOADING

A properly loaded vehicle is safe and easy to drive. Distribute your cargo evenly from side-to-side and from front-to-back. Load-leveling hitches are available; however, rely on some experienced recommendations to determine if your vehicle and tow vehicle are suitable for such a load-leveling hitch.

Heavier items should be stored as centrally as possible, on or near the floor. They should be secured so that they cannot slide during a sudden stop and cause damage. (Loose cargo can alter the balance you had when you started.) Lighter items can be stored in overhead cabinets or other areas. Remember to leave space and weight allowance for souvenirs and other items you may purchase during your travels. A properly loaded unit can help conserve fuel and can prevent excessive wear on your tow vehicle.

WEIGHT DETERMINATIONS

It is extremely important that you weigh your unit **before** you leave on a trip. Check the Gross Axle Weight Rating (GAWR) and the Gross Vehicle Weight Rating (GVWR) found on the Federal Sticker affixed to each vehicle. The Federal Sticker or certificate lists the unit Serial Number and the front and rear GAWR and GVWR. It is located on the left outside front corner of your vehicle. Your tow vehicle has a similar sticker. The ratings listed on each sticker is for the specific wheel and tire sizes listed.

We suggest that you record this sticker information in the space provided here to ensure that you always have the information close at hand.

GVWR _____ GAWR Front _____

GAWR Rear _____ with _____ tires

RIMS _____ at _____ PSI cold

You can weigh your vehicle at a grain elevator, sand and gravel dealer or government weighing station. Weigh your unit fully loaded. There may be a small fee for weigh-

ing your vehicle; however, it is an investment in safe traveling and peace of mind. Check your Yellow Pages for the address and telephone number of the weighing facility nearest you.

Note: *Exceeding the GVW and GAW ratings for your unit could result in serious damage to the suspension, frame or other components of your vehicle and void the warranty on those parts. Use of heavier suspension components (springs, shocks, axles) or heavier-ply tires does not increase the weight ratings printed on the tow vehicle's certification plate. The GAWR of each axle is determined by the axle system components with the lowest weight-carrying capacity. To avoid overloading your vehicle, check the GVWR and GAWR.*

WEIGHT DEFINITIONS

GVWR—(Gross Vehicle Weight Rating) means the maximum permissible weight of this vehicle. The GVWR is equal to or greater than the sum of the Unloaded Vehicle Weight plus the Net Carrying Capacity.

GAWR—(Gross Axle Weight Rating) means the allowable weight, including cargo, which can be safely supported by each axle.

UVW—(Unloaded Vehicle Weight) The weight of the unit with no fluids, cargo, optional equipment or accessories.

CARRYING CAPACITY—The difference between the UVW and the GVWR. This is the amount of weight available for all fluids, cargo, optional equipment and accessories. The actual "loaded" weight will depend on the equipped unit and the owner's individual choice of cargo, etc.

MFD. BY:	DATE			
INC. VEH. MFD. BY:	DATE			
GAWR LB	TIRES	PSI COLD SINGLE	PSI COLD DUAL	RIMS
FRONT				
INTER-MEDIATE				
REAR				
GVWR LB	MODEL NUMBER			
TYPE	VEHICLE I.D. NUMBER			
THIS VEHICLE CONFORMS TO ALL APPLICABLE FEDERAL MOTOR VEHICLE SAFETY STANDARDS IN EFFECT IN:				

FEDERAL STICKER

WEIGHING

TRAVEL TRAILER

Follow this procedure to weigh your RV and tow vehicle.

STEP 1—As shown in the illustration, pull your fully loaded and hitched-up trailer onto the scale; stop when only the trailer axles are on the scale. This will give you the Gross Axle Weight (GAW). The GAW must not exceed the Gross Axle Weight Rating (GAWR) of your unit. If it does, shift/remove cargo to achieve proper tolerance.

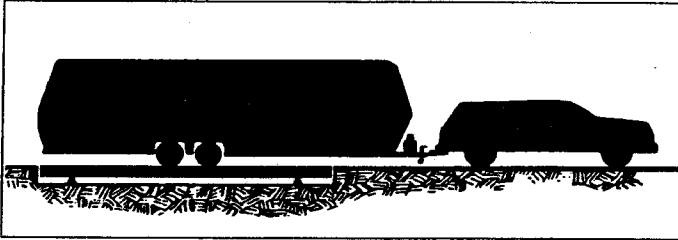

STEP 1—GROSS AXLE WEIGHT

STEP 2—Lower your front jack and unhitch the trailer so that only the trailer axles are on the scale. The front jack is off of the scale.

This will give you the GAW without any of the weight being shifted by a weight-distributing hitch (if one is used). Write down this weight. It will be used later to determine the hitch weight in STEP 4. The unit must be level to ensure accurate weights.

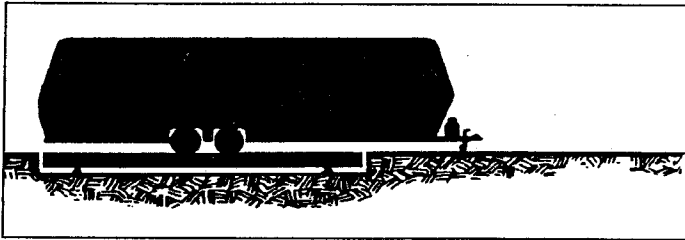

STEP 2—GROSS VEHICLE WEIGHT
(Without Weight Distributing Hitch)

STEP 3—Move the trailer so that the axles and front jack are on the scale. This will give you the Gross Vehicle Weight. This figure must not exceed the GVWR. If it does, remove cargo to achieve proper tolerance.

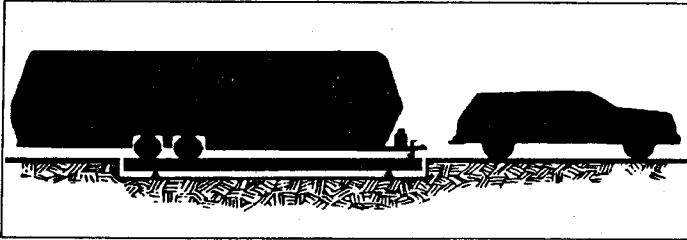

STEP 3—GROSS VEHICLE WEIGHT

STEP 4—Subtract the figure you obtained in STEP 2 from the figure you obtained in STEP 3 to arrive at the hitch weight. If the hitch weight exceeds 15 percent of the GVW, shift some of the trailer load to the rear. (When this is done, make sure you are not exceeding the GAW

that you checked in STEP 1.) This should give you the proper hitch load. If the hitch weight is below 10 percent of the GVW, shift some of the trailer load to the front to get the proper hitch load.

FIFTH WHEEL

STEP 1—As shown in the illustration, pull your fully loaded and hitched-up fifth wheel onto the scale; stop when only the fifth wheel axles are on the scale. This will give you the Gross Axle Weight (GAW). The GAW must not exceed the Gross Axle Weight Rating (GAWR) of your unit. If it does, shift/remove cargo to achieve proper tolerance.

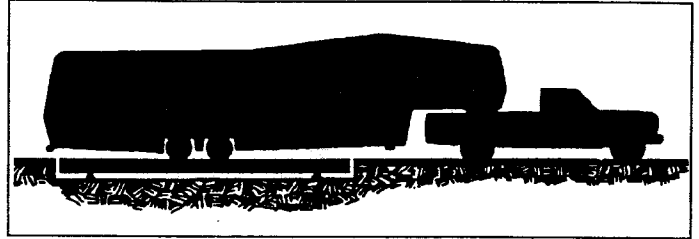

STEP 1—GROSS AXLE WEIGHT

STEP 2—To determine the pin weight of the fifth wheel, first weigh the tow vehicle fully loaded with cargo and passengers with the fifth wheel connected. Then disconnect the fifth wheel and weigh the tow vehicle alone. The difference will be the pin weight, which should not exceed 25 percent of the GVW of the fifth wheel. If it does, move articles around to make the proper tolerance. (When this is done, make sure you are not exceeding the GAWR that you checked in STEP 1.)

$$\text{GAW} + \text{Pin Weight} = \text{GVW.}$$

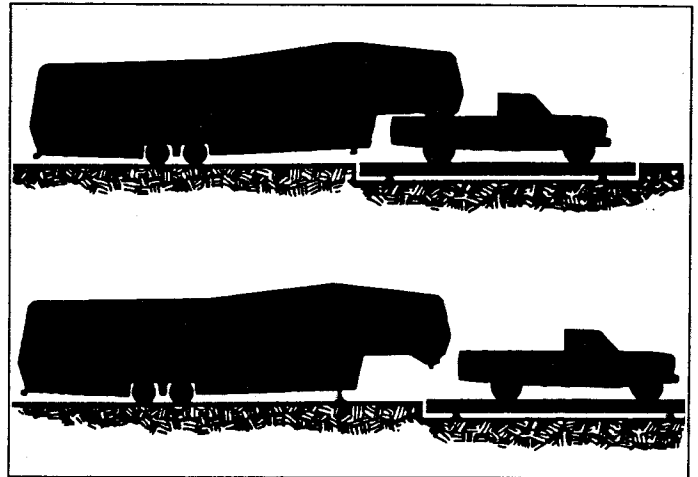

STEP 2—PIN WEIGHT

*** CAUTION ***

It is not recommended that you tow anything behind your travel trailer or fifth wheel. Damage could occur to the frame, and towability could be affected if weight is added to the back of the vehicle which takes weight off of the pin. You may also violate state laws pertaining to vehicle length, as well as voiding warranty coverage.

TIPS ON RELOADING

Avoid a drastic change in load placement when you camp. Try to have a place for everything and put everything back in its place.

Note: Refer to your tow vehicle owner's manual for additional information on towing and weight allowances or procedures to follow.

DRIVING

Get to know how your tow vehicle handles with the added weight of your RV. The brakes and steering operation will be different. Before leaving on a trip, practice making right and left turns, braking, backing and accelerating. Your RV is designed to travel at maximum legal highway speeds under ideal conditions. Under less than ideal conditions, your vehicle should be operated at reduced speed and it should never exceed the posted legal speed limits. Before you travel be sure to read APPENDIX A: PRE-TRAVEL CHECK in this manual. Below are tips to help you.

CLEARANCE

Be sure to read "Clearance Height" signs on overpasses, drive-through windows, etc. Watch out for overhanging tree branches, awnings or similar obstructions that can damage your vehicle's roof or roof-mounted equipment and accessories. Check with your dealer for clearance measurements of the unit.

PULLING INTO TRAFFIC

Check for oncoming traffic in all directions. Signal before entering the flow of traffic. Always accelerate slowly and smoothly; the added weight of your RV makes quick acceleration not only difficult but potentially unsafe.

PASSING

Avoid sudden maneuvers when passing a slower moving vehicle. Remember that additional time and distance are required to pass safely. Wait until the road is clear of oncoming traffic for at least 1/2 mile. Check the outside rearview mirrors and signal lane changes before passing other vehicles. When you have safe clearance, signal lane change and return to your original lane.

BRAKING

Allow a safe distance to stop; follow no closer than one combined tow vehicle/RV length for each 10 mph. A sudden stop may cause your unit to jackknife. For detailed information about your RV's brake system, see APPENDIX C: TRAILER BRAKES in this manual.

BACKING

It is extremely important that you back the RV slowly. Trying to maneuver the RV as you would in normal driving could cause the unit to jackknife, hit your tow vehicle or cause other damage. The same hazards could result from turning the wheels too sharp when you back the vehicle or when you are driving normally.

Backing the unit may require stationing someone beside the unit to guide the driver. When backing your RV; place your right or left hand at the bottom of the steering wheel. To move the trailer to the left, move your hand to the left; to move the trailer to the right, move your hand to the right. If the trailer starts to jackknife, stop, pull forward and start the procedure again.

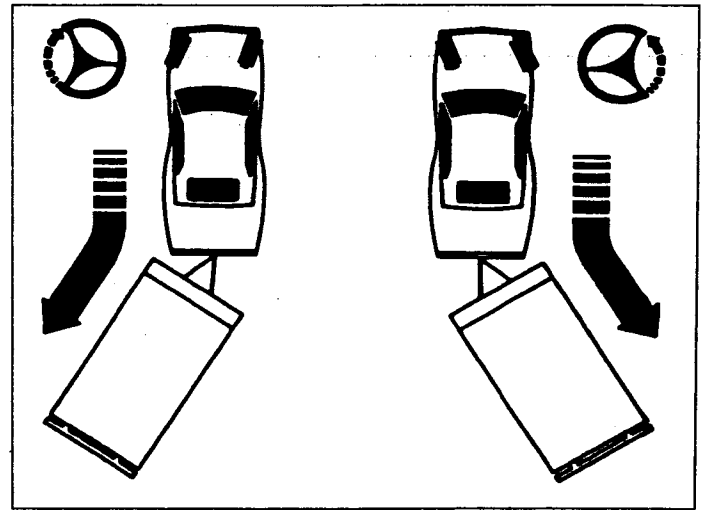

BACKING TRAILER OR FIFTH WHEEL

If you have never backed a tow vehicle and trailer before, it is almost always a good idea to practice backing in an empty parking lot before you "hit the road." Your dealer will usually be willing to assist you by teaching you maneuverability techniques.

SWAYING OR FISHTAILING

If this happens while you are towing a vehicle, accelerate slightly and then gradually slow down. If your unit still sways, pull off the road and check the following:

1. Height of equalizer hitch,
2. Distribution of cargo,
3. Tire pressure, and
4. Tow vehicle front-end alignment and suspension.

TURNING

The wheels of your RV are set wider than those of your tow vehicle. Pull several feet farther ahead before turning. This will compensate for the extra width and length of your RV and will help you avoid hitting curbs or parked vehicles.

DOWNGRADES

When you are going downhill, reduce your speed and shift the transmission to a lower gear to assist in braking on long or steep downgrades.

UPGRADES

To avoid engine overheating when climbing a steep grade, reduce speed and shift the transmission to a lower gear.

PARKING ON A GRADE

Parking vehicles on an upgrade or downgrade is not recommended. If it is necessary in an emergency, apply the brakes and have a passenger place wheel chocks behind the tires of your RV. When in place, slowly release brakes until the unit is stopped by the chocks. Apply parking brake and shift transmission into PARK position (place manual transmission vehicles in gear).

FREEDING A STUCK VEHICLE

To pull your unit out of the snow, sand or mud, apply slight pressure to the accelerator pedal and move the gear selector rhythmically between first gear and reverse gear. If possible, keep the front wheels pointed straight ahead. Avoid sharp turns. Once the unit starts to move, do not stop until it is on firm ground.

CAMPING

CAMPSITE SELECTION

There are many campground guides that will assist you in making your selection. Many campgrounds accept reservations, and during peak seasons, it is wise to make a reservation. If possible, arrive early so you can inspect and choose your campsite during the daylight hours.

During the winter months it is desirable to take advantage of natural windbreaks like trees, bushes or any similar type of windbreak. This will cut down the possibility of cold drafts that can affect the comfort level of your unit.

SET-UP

It is very important that your unit is level. This allows your refrigerator and drainage systems to operate properly (both function by gravity). To level your RV, place a level on the bottom of the refrigerator's freezer compartment or on a normally level location inside the vehicle. You may wish to permanently attach levels (available at your dealer) on the front and/or back and sides of the RV. This will allow you to tell at a glance if you've stopped on a level site and will help speed the leveling process.

SIDE-TO-SIDE LEVELING

If the unit needs side-to-side leveling, make a step leveling ramp on the low side out of 1x6" or 2x6" boards of varying lengths. Pull the unit forward or back onto the leveling ramp until the low side is level. Many experienced RVers carry level boards or blocks in their unit for this purpose.

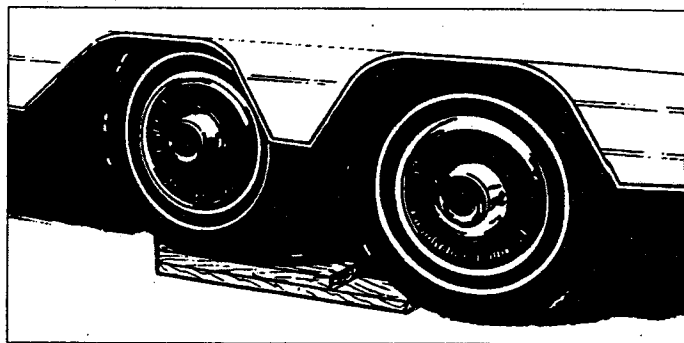

STEP LEVELING RAMP

FRONT-TO-BACK LEVELING

TRAVEL TRAILER

To level a travel trailer from front-to-back, prepare to unhitch the unit from the tow vehicle by installing the dolly wheel/jack foot and crank or run the front jack down. Never rest the unit on the front jack without the dolly wheel/jack foot being attached, or without a board under it. (A dolly wheel/jack foot is not recommended with a power jack.) If the ground or surface is soft, place a board under the dolly wheel/jack foot or jack. Disconnect the safety chains, the pigtail and the breakaway cable from the tow vehicle. Move the front jack up or down until the unit is level.

Jack stands (available from your Coachmen dealer) may be placed under the frame to eliminate sway when persons move about inside the unit. If you use a jack stand, lower the front jack about two inches below level. Place a jack stand under both main frame members—NEVER AGAINST THE FLOOR—at the rear of the trailer. Raise each jack until it touches the frame. Raise the front jack about two inches above level, and place jack stands under the main frame members near the front of the unit. Raise the jacks until they touch the frame, then lower the front jack to level.

Helpful Hint: Using blocks under the jacks will help keep the unit level and won't allow the jacks to sink into the ground.

Some RVs will have installed, for your convenience, permanently-mounted stabilizing jacks. If your unit has these unhitch the unit and, using the unit's front jack, get a front to rear level. Check level for low side of trailer (some camping sites are not level and it will be necessary to use a leveling ramp on the low side of the trailer). Lower the stabilizing jacks on the LOW side of the trailer to a level position. Lower the stabilizers on the opposite side of the trailer to the ground and firm up. An angle of 55 to 60 degrees on the jack legs provides the best stabilization. Before moving your trailer, crank the stabilizers to the fully closed position, and give quarter turn to tightly secure.

Note: Stabilizer jacks are designed for STABILIZING only. Do not attempt to use them to support the full weight of the trailer.

If your unit has a power front jack, you might have to remove the switch cover to run the jack up or down. The switch is spring-loaded and will return to the OFF position when released. If your power jack has a switch cover, be certain to replace it when the switch is not in use. Familiarize yourself with the direction and travel of the jack post and the corresponding switch direction

FIFTH WHEEL

To level the fifth wheel, lower the front jacks. Place a board under each jack foot. Disconnect pin hitch, pigtail and breakaway cable. Remove or lower tailgate and move truck away. Level unit by moving jacks up or down. Install jack stands at the rear of the fifth wheel by lowering the front jacks two inches below level and placing jacks under the rear main frame members—NEVER AGAINST THE FLOOR. Raise these jacks until they touch the frame. Level by raising the front jacks.

SLIDE-OUT ROOM OPERATION

Certain models of fifth wheels and travel trailers are equipped with slide-out rooms. **The stabilizing jacks must be set up if the slide-out room is in the out position.**

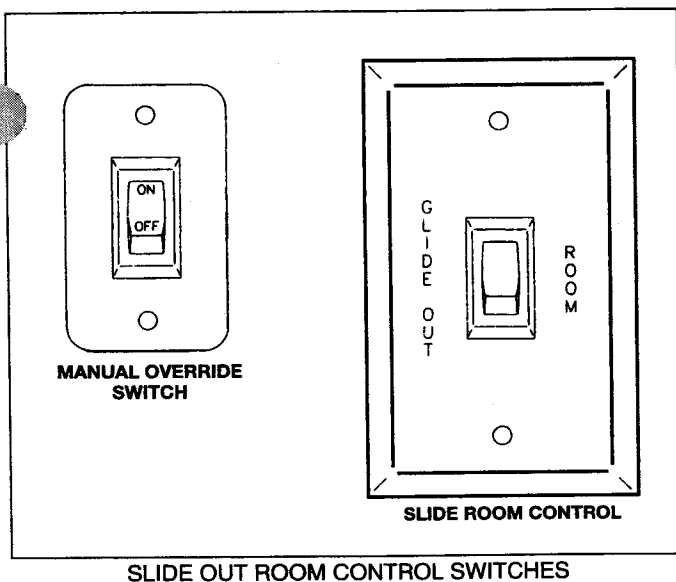

*** CAUTION ***

Be sure that you remove or unlock any devices that are used to lock the room in the closed position.

ELECTRICAL

To operate the slide-out room, lower the stabilizer jacks. Push the switch on the inside of the unit to the "out" position and hold the switch down until the room is fully extended.

To bring the room in, depress the switch in the "in" position until the room is fully retracted. Be sure to retract the stabilizing jacks before moving the unit.

In the event that battery power is not available (must have a minimum of 11 volts and 10 amps), the room can be extended manually. After extending the stabilizer jacks, push the manual override switch located by the slide out room switch to the "OFF" position. The room can then be manually cranked out.

It is important that the manual override switch remain in the "ON" position unless the room is being manually retracted, or the unit is going into storage. When the manual override switch is turned off the power to the motor is turned off which causes the motor resistance to relax. When the motor resistance is relaxed the room will not stay sealed. After the room has been retracted the manual override switch needs to be turned back on. This will hold the room in place.

Note: *If the room is extremely difficult to crank, depressing the slide out switch may help release the brake.*

LIVING AREA

AIR QUALITY

State-of-the-art construction and energy conservation methods have been used in manufacturing your recreational vehicle. These improvements have substantially reduced air infiltration and air exchange, making them almost airtight. Therefore, periodic airing of your unit is recommended on a regular basis, especially during periods of high temperature and high humidity, and after prolonged storage.

CONDENSATION

Condensation can be a problem in modern, tightly-constructed, well-insulated RVs. Certain amounts of condensation should be expected, especially on cool surfaces such as windows, roof vents, and metal door frames. However, when there is excessive condensation—the troublesome kind that blocks all windows with fog or frost—damage to walls, woodwork and ceilings can occur.

Remember that sweating windows are a signal indicating that moisture is trying to get out to mix with drier air.

CONTROLLING CONDENSATION

When the unit is closed tightly, especially in cold weather, the small air volume in your RV can absorb only a certain amount of moisture. Bathing, dish washing,

laundry appliances and unvented gas burners are among the causes of added moisture in the air. You can control the amount of moisture in the air by allowing the moisture to escape to the outside. Use your vent hood and fan when you cook; keep the bathroom door closed and the vent or window open while you bathe or shower (and for a short time after you have finished bathing or showering, to allow all the moisture to dissipate); don't hang wet clothes in your unit; and if you have a clothes dryer, be certain it is vented to the outside.

Note: Condensation can cause your RV's insulation to become damp, reducing its insulation properties.

TABLES

Listed below are general instructions for setting up the variety of tables and beds that may be found in your RV. Your dealer will be happy to demonstrate these items.

SWING UP TABLE

To raise the swing up table, pull the table toward you and up; then push it toward the wall. Insert tabs at back of table into the wall brackets. Pull the leg down and adjust to the proper height. To lower the table into the bed position, reverse the above operation.

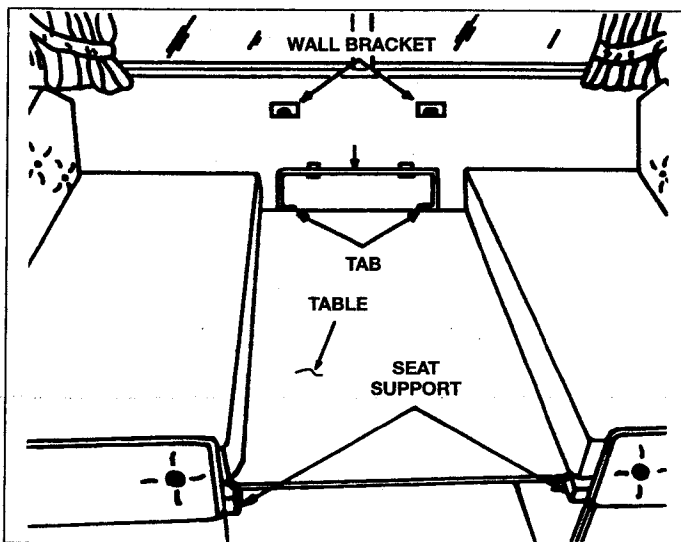

SWING UP TABLE

PEDESTAL TABLE

Insert table leg into base plate. Lower table support bracket onto the leg.

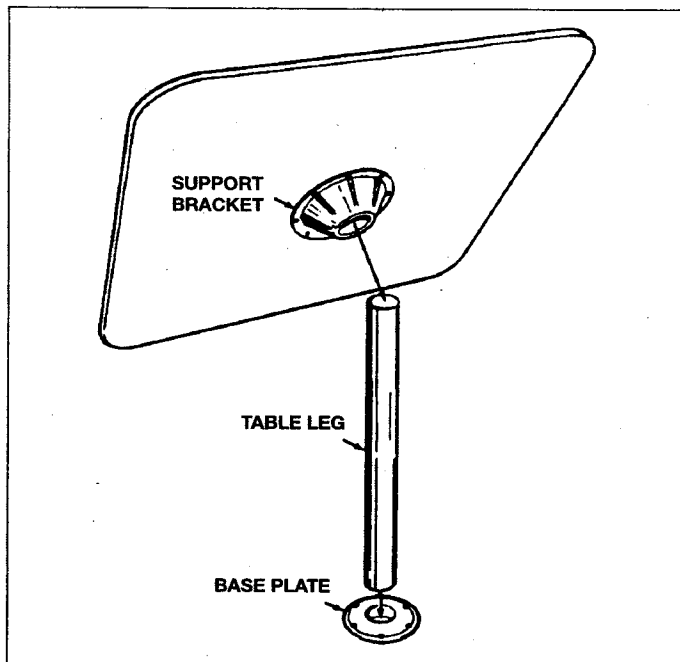

PEDESTAL TABLE

BEDS

GAUCHO

Lift the front edge of the lounge platform and slide it out. Arrange cushions on the platform.



GAUCHO BED

CABINET HIDE-A-BED

(Located either in the front or rear of your RV). Release the latches located at each end inside of the cabinet. Close and latch the cabinet doors. Swing the cabinet front down so that it rests on the supports. Install the reinforcing boards and arrange cushions on the platform.

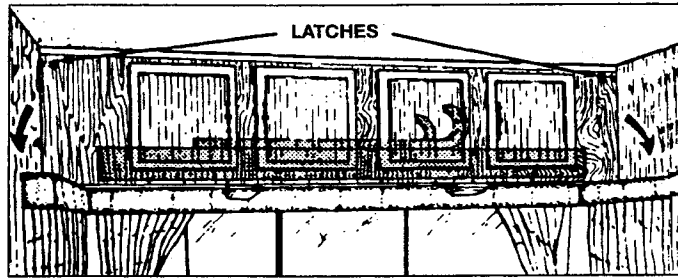

HIDE-A-BED

SOFA

Several types of sofas are used. Talk to your dealer for proper instructions for the sofa in your particular unit.

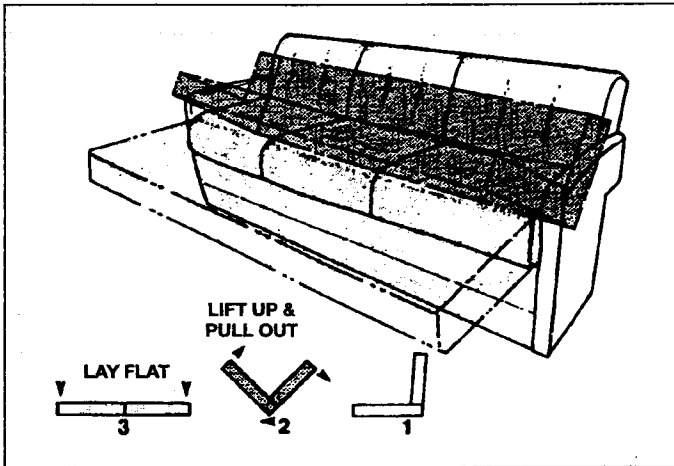

JACKKNIFE SOFA

DINETTE BED

For those with swing tables, move the leg to the "UP" position and pivot the table down to the dinette seat supports. Place the table on the seat supports and arrange the cushions on the top.

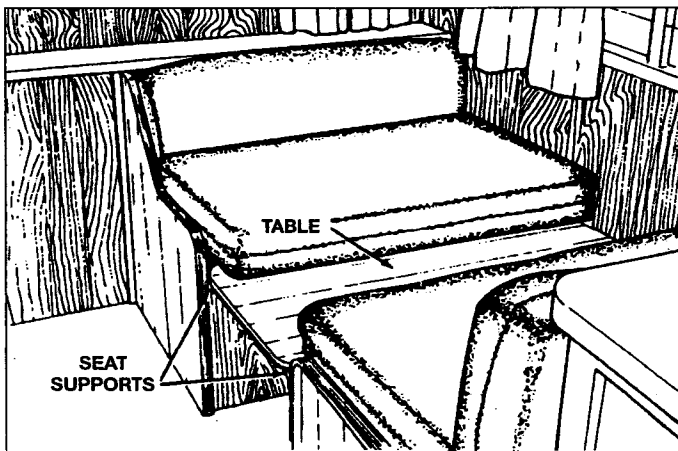

DINETTE BED

BASIC UTILITY SYSTEMS

This section will describe the four basic utility systems found in your RV. They are: Electrical, Fresh Water, Drainage/Sewer and LP Gas. The following will familiarize you with their function, operation and simple maintenance. If a problem should develop with any of the systems, contact your authorized Coachmen dealer for service.

MONITOR PANEL

This allows you to check the condition of your RV battery and the volume of fresh, waste and gray water in your unit's holding tanks, the water pump and water heater switch. The "C" on your battery monitor stands for charge and is not a battery level. The monitor panel illustrated is typical; the one in your unit may look and function differently. Your Coachmen dealer will be happy to explain the operation of your monitor panel.

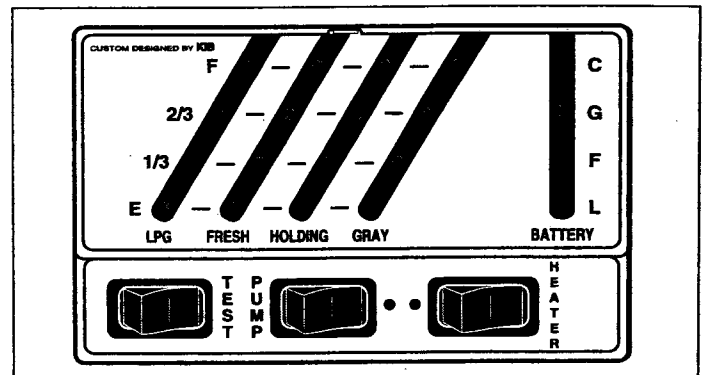

POWER RANGE & MONITOR PANEL

BATTERY CONDITION LEVELS

The battery condition will fall into one of the following levels:

- C** Charge, more than 14.5 volts (unfiltered circuit or dead cells in battery).
- G** Good, 12.6-14.49 volts.
- F** Fair, 12.0-12.5 volts.
- L** Low, 5-11.9 volts.

RANGE HOOD

The light and fan of your power range hood are controlled by switches on the front. Use the fan to draw smoke and cooking fumes out of the unit. For metal surfaces, use the same procedure as for the range top. For the power hood, clean the plastic light cover by removing and washing it. If the light burns out, replace it with a bulb of the same size and wattage. To clean the power hood filter, push slot located in center front of screen and pull down. If not greasy, simply tap the filter to shake out the dirt. If the filter is greasy run hot, soapy water over it until grease dissolves. Allow the filter to drain and dry, then replace by positioning the flanges, push into place.

The gravity hood can be cleaned by gently rubbing a soapy cloth over screen.

ELECTRICAL SYSTEM

Your recreational vehicle contains two (2) separate electrical systems: one 12-volt direct current (DC) and one 120-volt alternating current (AC), similar to the one in homes. These systems provide you with power while you are camped or are traveling. The 120-volt system requires an external source of 120-volt electricity, usually a campsite or household receptacle or an auxiliary generator. The 12-volt electrical system is supplied by batteries, the power converter or the 12-volt source from the tow vehicle.

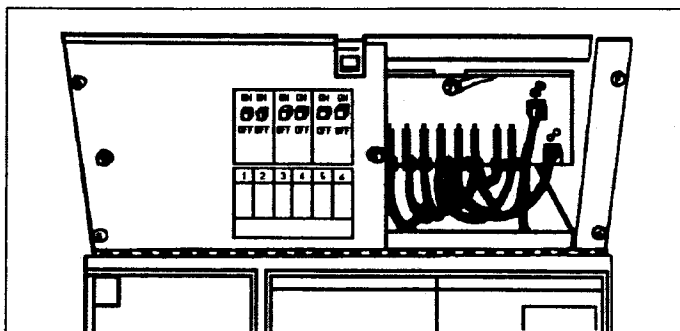

COMBINED POWER CENTER/CONVERTER

Operational instructions are located inside power center door

To reduce the 12-volt load on your RV batteries, the 120-volt system should be used whenever a 120-volt hook-up is available. Although most components in your unit (water pump, range hood light and fan, interior lights) operate only from a 12-volt source, the power converter changes 120-volt AC to 12-volt DC power.

120-VOLT SYSTEM

The 120-volt system supplies power for the following through the power center: refrigerator, exterior receptacles, interior receptacles (used to operate regular household appliances), and optional roof air conditioner. The converter provides 12-volt power for all of the unit's 12-volt components. When the external 120-volt power cord is used, the power is connected directly into the main electrical service panel of the power center and is distributed through circuit breakers.

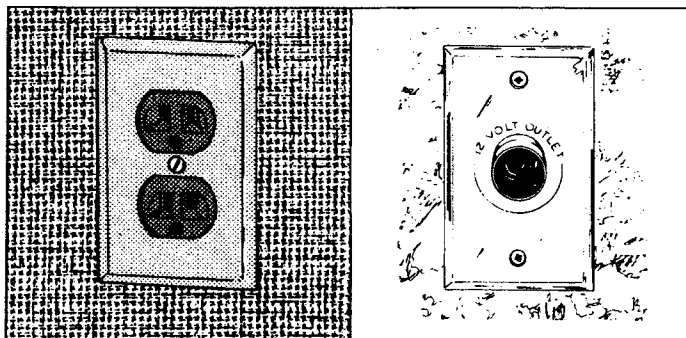

120-VOLT AND 12-VOLT RECEPTACLES

GROUND FAULT INTERRUPTER/RECEPTACLE

The bath, kitchen and exterior receptacles are protected by a ground fault interrupter (GFI). The GFI is built into the bath and kitchen receptacles, and connected to the outside receptacle. It protects against severe electrical shock, if a ground fault occurs in that circuit. The GFI will not trip due to an over current condition. The GFI senses the fault and breaks the bath, kitchen and exterior receptacle circuits. If this should happen, unplug all appliances on that circuit and reset the breaker in the bath or kitchen receptacle.

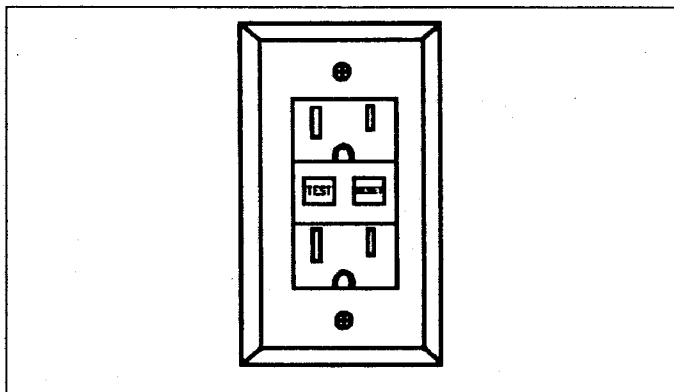

GFI RECEPTACLE

The GFI system should be tested at least once a month. To test the GFI system, plug a test light into the outlet and push the "Test" button on the receptacle. The test light should go out. To restore power, push the "Reset" button. If the button does NOT pop out or if the test light indicates a live circuit, DO NOT use the outlets. Contact your Coachmen dealer.

SHORELINE CONNECTION

The shoreline is a heavy-duty cable with a 3-prong grounding plug on one end, permanently attached at the other end, and connected to the power center. It can be pulled from its storage compartment through a hatch in the sidewall of your vehicle and connected to a matching receptacle. Some campsites and trailer parks still have two-slot outlets. If it is necessary to use a 3-to-2 adapter, be certain its grounding wire is fastened securely to the outlet grounding screw.

If your unit is equipped with two air conditioners, wiring for a second air conditioner, or a combination washer/dryer, you will have a 50 amp service with a heavy-duty cable and a 4-prong plug. If it is necessary to adapt from the 50 amp plug to a 30 amp receptacle, you will not be able to operate these options.

The 120-volt system is protected by the circuit breakers. If a circuit breaker opens, unplug the appliance(s) on that circuit, allow a short period for the breaker to cool, and reset the breaker. If the breaker continues to open, it may be caused by an appliance you have added, or a fault in the electrical system. If you determine it may be a fault in the electrical system contact your Coachmen dealer.

POWER DISTRIBUTION CHART

POWER CENTER AND/OR 12-VOLT BATTERY	120-VOLT ELECTRICAL
All interior lights	Power center
Porch light	All receptacles
Trunk lights	Refrigerator
Radio	Air conditioner(s)
Water pump	Microwave
Monitor panel	Washer/dryer
Range vent	Television
Power roof vent	VCR
Slide-Out Room	Stereo
Television (front & rear)	Water Heater
Television antenna	
Water heater (electronic ignition)	
Furnace (electronic ignition)	
Grab handle (lighted)	
LP leak detector	
Refrigerator	

***Canadian (CSA) units equipped with an electronic water heater and a microwave oven.** There will be a wall switch that will allow you to operate only one of these appliances at a time.

12-VOLT SYSTEM

The 12-volt system, includes the automotive battery and the RV battery, plus the 12-volt converter. To use the automotive battery the electrical pigtail must be attached to your tow vehicle. This provides power to the exterior lights and brakes in addition to all inside 12-volt appliances. The RV battery and/or 12-volt converter provide power to all inside appliances (lights, range hood, furnace blower, water pump, 12-volt receptacles, porch light, monitor panel and refrigerator). The shoreline must be attached to run the converter.

The automotive alternator will charge the RV battery when the pigtail is attached. When the shoreline is attached, the RV battery will be charged by the 12-volt converter.

The pigtail should be disconnected from the tow vehicle when the RV battery is in use.

BATTERY

The liquid level in the battery must be above the plates. It should be checked frequently (daily during heavy usage). The battery manufacturer recommends using a good grade of drinking water (not mineral water). The battery terminals should be kept free of dirt and corrosion. Also, the charge level of the battery should be checked. (You may use a battery hydrometer to do this.) When specific gravity is below 1.225, recharge the battery until the 1.265 level is indicated.

To check the battery using the monitor panel, disconnect the shoreline and turn on at least three interior lights. (A discharged battery will show full charge unless some electricity is being drawn.)

CONVERTER

The power converter section of the power center transforms 120-volt AC into 12-volt DC to supply power to all of the 12-volt systems. Each 12-volt circuit is protected by a fuse in the power center. Turn the twist lock to open the door and check the fuses. A listing of the circuits is on the inside of the door. Some fuses protect circuits with more than one function; others may be for specific appliances.

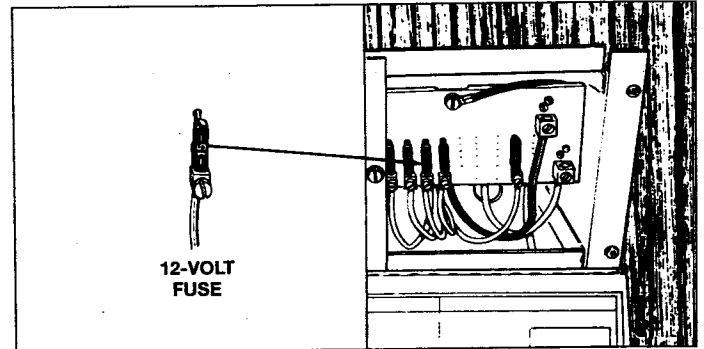

12-VOLT FUSE BLOCK

If a fuse is blown, turn off or unplug all appliances on that circuit. Replace the blown fuse with one of the same ampere rating. If the fuse continues to blow, notify your Coachmen dealer. See the power center manufacturer's manual for specifications, operation and testing procedures.

*** CAUTION ***

DO NOT replace a fuse with one of a higher AMP rating.

FRESH WATER SYSTEM

Fresh water for your unit is supplied either by the vehicle's fresh water tank or by an external pressurized source (city water).

The water heater (either match light or electronic ignition) is an LP gas appliance that heats water to a preset temperature. To fill the water heater, simply turn on a hot water faucet. When water flows steadily, turn the faucet off.

CITY WATER

When using the city water hookup, the water tank and pump are bypassed. You cannot fill the water tank through the city water inlet. Connect a hose to a "city pressurized" water faucet and to the RV's fresh water inlet.

Although a common garden hose can be used to fill the water tank and connect to city water, long-time RVers recommend a hose specifically manufactured for this, available at your Coachmen dealer.

Note: In areas where city water pressure exceeds 60 psi, a pressure regulator should be used. Excessive water pressure may damage lines and connections. See your authorized Coachmen dealer for more details.

WATER TANK

Because of a variance in weight distribution, the water tank may be beneath a gaucho, dinette, bed or kitchen cabinet or under the floor of the unit. To fill the water tank, open the gravity water fill. Use a hose or vessel to fill the water tank. Water will flow out of the water fill when the tank is full.

The water tank should be sanitized before you use it for the first time; after a period of non-use; and whenever you suspect the tank is contaminated. To sanitize your water tank, first empty the tank and then use the following procedures:

1. Pour 2-1/2 cups of liquid household bleach along with approximately 10 gallons of water into the fresh water tank.
2. Turn the vehicle's water pump on. Open the hot water faucet until water begins to flow. Turn off hot water and repeat with the cold. Wait three hours.
3. Open faucets, line drains, water tank and water heater drains. Some solution will remain in the water heater.
4. Fill the water tank to the 1/2 level. Turn on the water pump and open all faucets. Let the water run until the system is empty. Connect a hose to the city water fill. Turn on all faucets and let the water flow for about five minutes.
5. If a chlorine taste lingers, flush the system with a vinegar and water solution (one quart of vinegar to five gallons water). Wait two to three hours and flush with fresh water.

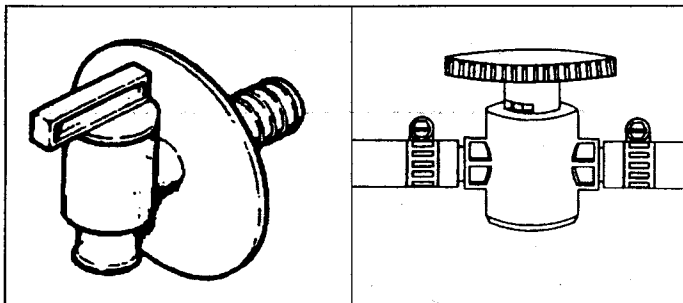

WATER TANK DRAINS

WATER PUMP

The water pump is a 12-volt DC appliance that is activated by a switch on the monitor panel mounted in the kitchen area. (On some models a second switch may be located in the bathroom). The switch can be left on while camping. When you want water, simply open a faucet. The pump which supplies water from the fresh water tank will run only as long as is needed. If the pump

fails to start when the switch is on, check the fuse located in the converter. If the pump continues to operate whether the faucets are opened or closed, check the water tank.

If the pump runs sporadically; the tank may be empty or there might be a leak in the system. If the city water is connected, the pump is not required, and should be turned off. See additional information in the manufacturer's manual.

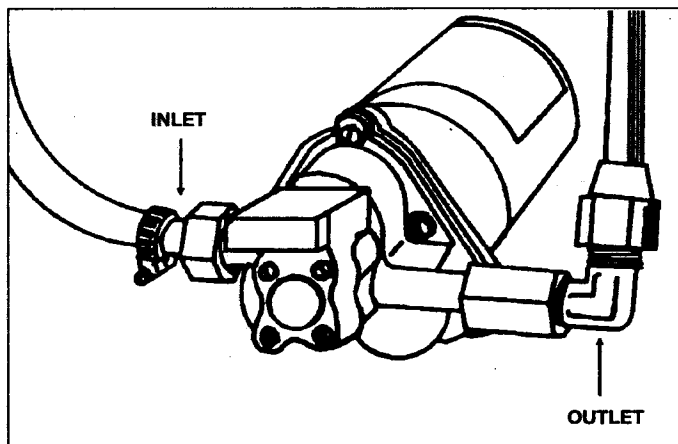

WATER PUMP

SINKS

Clean the kitchen and bathroom sinks with nonabrasive cleanser. Stainless steel cleaner may be purchased at most grocery stores. ABS cleaner, such as Aqua K-7, may be purchased from your authorized Coachmen dealer.

LEAKS

Traveling over bumpy or rough roads can cause pipe fittings to loosen. Check the pipe fittings in your unit regularly for signs of leakage.

SHOWER

A shower hose anti-siphon device is installed on your faucet to prevent the possibility of backflow.

DRAINAGE/SEWER SYSTEM

Your RV is equipped with a drainage sewer system that functions much the same as the one in your home. In most units, this system includes drain lines from the kitchen sinks, lavatory, tub/shower and marine type toilet to a gray-water holding tank and/or a sewage holding tank.

The drainage system also includes vents that carry odors (caused by drain water and waste) out through the roof. The drainage system vents also equalize the air pressure, which is necessary to maintain a water barrier against odors in the P-traps and to ensure smooth flow and escape for your drainage system.

TOILET

Flush the toilet before initial use and after emptying the holding tank, this will help to prevent collection of solids. To help control odors, there are a number of toilet and holding tank treatment concentrates on the market. These chemical concentrates are available at your Coachmen dealer.

The following illustrations show the two toilet models used in Coachmen RVs. To operate Toilet A, step on the small pedal to add water to the bowl. When you have the desired amount of water in the bowl, slowly release the pedal. To flush this type of toilet, step on the large pedal until the water swirls and then slowly release the pedal.

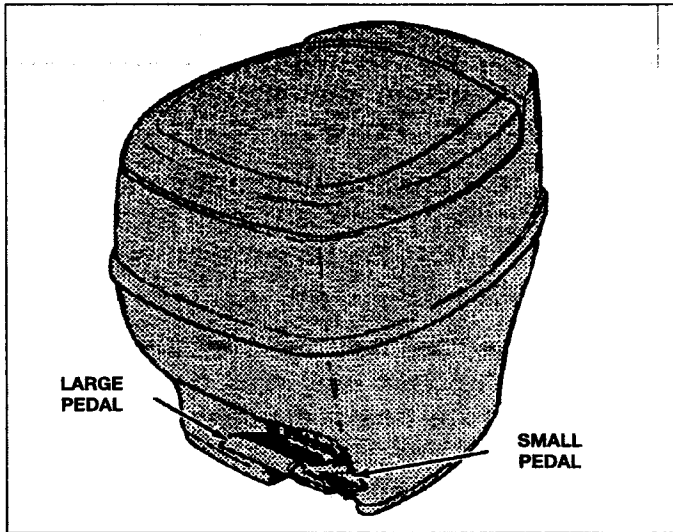

TOILET A

To operate Toilet B, pull the black lever, which empties the bowl, forward (the "open" position) and hold until all contents are swept into the holding tank. Always hold the black lever in the "open" position for a minimum of three seconds. The black lever simultaneously activates the white lever. When you release the black lever, the bowl will automatically fill with water for the next use. To add more water to the bowl, pull the white lever forward.

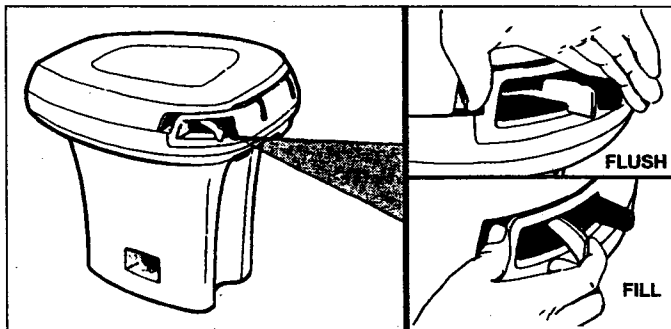

TOILET B

When you clean your toilet, do not use highly concentrated or highly acidic household cleaners (no scouring powder). If the slide valve does not move freely, apply silicone spray. To ensure proper operation and maintenance, refer to your toilet manufacturer's operating manual.

HOLDING TANKS

Most unit drainage/sewer systems have two holding tanks: Gray Water and Waste (black) Water. The gray water holding tank collects water from the kitchen sink, lavatory and tub/shower. The waste (black) water holding tank is used to collect waste from the toilet.

To prevent unnecessary accumulation of solids in the waste holding tank, do not put facial tissues or similar products into the toilet. It is highly recommended that you use only bio-degradable toilet tissue available from your RV dealer. Holding tanks should be emptied frequently into a specified dumping station. Most campgrounds have dumping stations, often at each campsite, and many service stations and highway rest areas have waste dumping stations also. Before emptying the holding tanks, make sure your vehicle is level; emptying the holding tanks depends on gravity.

To empty the holding tank, remove the sewage drain hose from its storage area. Remove the cap from the termination outlet and connect the sewage drain hose.

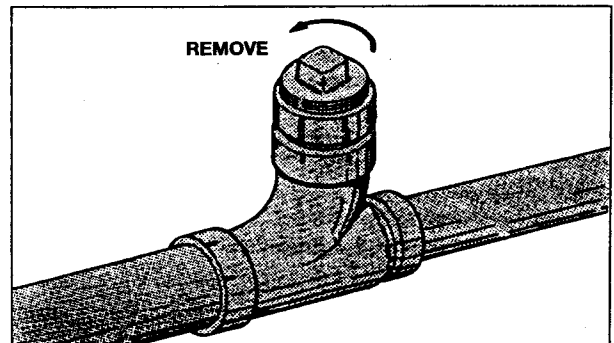

DRAIN CLEANOUT

Do not use harsh drain cleaner chemicals or solvents in the drains. Drain cleanouts are installed on certain units at intervals to facilitate drain line cleaning or unclogging. Use a wrench to remove and replace drain cleanout plug.

While you are camped you may leave the gray water dump valve open only if the hose is connected and your campsite has a sewage hookup. Do not open the waste water dump valve until you want to empty the holding tank. If the waste water dump valve is left open, the rinse and flush water will run off and solids will be left to collect and harden in the bottom of the tank.

To drain a holding tank, pull out the dump valve slide handle. On some units it is necessary to unfasten a locking device before the slide valve handle can be pulled out. After the tank is drained, close the valve (if applicable, lock in place).

After emptying the waste holding tank, flush or pour about two gallons of water through the toilet and drain again. This flushes the tank and helps clean the drain hose. Repeat as necessary.

To empty the gray water holding tank, follow the same procedure used to empty the waste holding tank. A flushing may not be necessary. When the tank is empty push the dump valve handle in until it seats (if applicable, lock in place). Remove the hose, wash it and return it to its storage holder. Replace the termination cap securely.

If your model is equipped with an outside shower this may be used to rinse out the inside of your sewer hose before leaving the dump facility.

It is recommended that you always drain the sewage waste holding tank first, and then the gray water tank. This assists in flushing and cleaning the termination valve and drain hose.

LP GAS SYSTEM

The liquefied petroleum (LP) gas system in your unit furnishes fuel for hot water, heat, cooking and refrigeration (see illustration). LP gas provides a portable, efficient and inexpensive source of energy. It is stored in a LP gas bottle(s) on the "A" frame of travel trailers or inside a compartment on fifth wheel trailers.

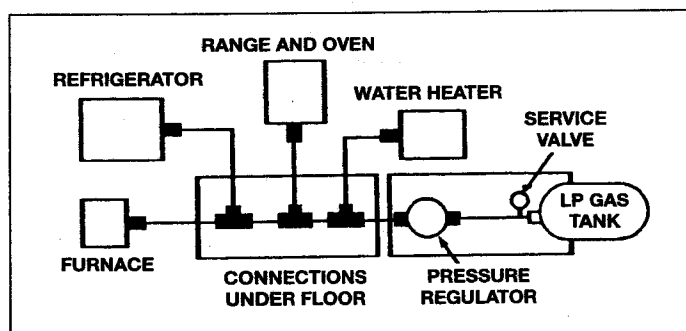

LP GAS SYSTEM (TYPICAL)

Under pressure in the tank, the LP gas turns to vapor; it is the latter that burns. Each tank has a manual 80 percent stop-fill valve that allows space in the tank for vapor expansion. The high pressure of the vapor in the tank is reduced in two stages through a regulator. The tank pressure will vary with temperature and altitude, but may be reduced to about 12 psi in the first stage, then to about 6-1/4 ounces in the second stage (the 6-1/4 ounces per square inch also is expressed as 11 inches of water column).

* CAUTION *

LP gas is usually propane or a blend of propane and butane. When you fill your tanks, be sure to use propane ONLY. Do not use butane or butane mixtures.

The LP gas system is designed and built to meet rigid standards, and it is tested before it leaves the factory. Your dealer also tests the system before it is delivered to you. Always take your vehicle to an autho-

rized dealer for LP gas problems. Always have an authorized LP gas supplier fill your LP gas tanks.

LP gas burns readily and with intense heat. With proper care and maintenance, it is safe and efficient. There are, however, certain characteristics about LP gas you should know. LP gas settles into any closed area, it displaces air and could cause suffocation if not detected. It also could create a fire or explosion hazard. In its natural state, LP gas is odorless. An additive gives it a distinctive mustard odor so that leaks can be readily detected. Under certain circumstances you may not be able to detect LP gas by smell. For that reason, your vehicle is equipped with an LP leak detector which will provide an audible warning if a propane leak is detected. Never disable or bypass this critical safety device. The following label has been placed in the vehicle near the range area:

WARNING!

If you smell or think you smell gas:

1. Extinguish any open flames, pilot lights, and all smoking materials.
2. Do not touch electrical switches.
3. Shut off the gas supply at the tank. CLOSE valve(s) or gas supply connection.
4. Open doors and other non-electrical ventilating openings.
5. Leave the area until the odor clears, and
6. Immediately call your gas supplier, and have the gas system checked and leakage source corrected before using again.

Before using any LP gas appliance, read the respective manufacturer's operating instruction manual.

* CAUTION *

LP gas containers should not be placed or stored inside the living area of a vehicle. LP gas containers are equipped with safety devices that relieve excess pressure by discharging gas to the atmosphere.

CLIMATE DIFFERENCES

An appliance will not function if the LP gas does not vaporize. Propane continues to vaporize down to -44 degrees F. Liquid gas does not vaporize as rapidly in cold weather, so you may place too great a demand on your tanks' capacities in certain conditions. This can cause a refrigeration effect resulting in frosting of the tank and regulator. Check with your dealer or LP gas supplier about the appliance demands that can be met by your tank at various temperatures. Always have your LP gas supplier add anhydrous methanol before filling the tank in cold weather.

Propane has become the main type of LP gas used in RVs. It is recommended that you use only propane gas. The names of LP suppliers can be found in the Yellow Pages of your telephone directory under "Gas-Liquefied Petroleum-Bottled and Bulk." Many campgrounds now have LP fill facilities, as do some service stations.

To operate any LP gas appliance, the LP gas SERVICE valve must be open. When first used, or after a refill, there may be some air in the gas lines that will escape when you first open a range burner or similar LP gas valve. The air may extinguish your match or igniter the first time or two before you get ignition. Remember too, that when you close the tank's SERVICE valve some of the gas will remain in the lines. To completely bleed the lines of gas, close the tank's SERVICE valve and light a range burner to use up the excess. When the flame burns out, turn the range burner off.

REGULATOR PRESSURE

Check the LP gas regulator at the beginning of each season or whenever a problem is indicated. Correct line pressure is 11 inches of water column. Your dealer or LP gas supplier can perform this check.

LP gas regulators must always be installed with the diaphragm vent facing down. Regulators that are not in compartments have been equipped with a protective cover. Make sure that the regulator vent faces down and that the cover is kept in place. This will minimize vent blockage that could result in excessive gas pressure and could cause a fire or explosion.

LP LEAK DETECTOR

The LP leak detector in your Coachmen RV should be in the ON position whenever you are using your RV. The most important feature is an early warning gas alarm ability and a malfunction indicator. If gas concentrations reach a level of only 1/4 the danger level periodic audio alarms and visual flashing are activated. There are periodic tests to perform to insure safety. Please be sure to read the manufacturer's instructions for maintenance and trouble shooting guides. They system should be turned off when the RV is in storage or will be unused for several days.

Do not spray any cleaning fluids near the detector. If the indicator light is not on, check the in-line fuse behind the detector.

REGULATOR/CHANGEOVER

Each pair of LP gas bottles will have a regulator. Double 20 lb. bottles may have a manual changeover valve; double 30 lb. bottles may have an automatic changeover valve. With the manual valve, open only one bottle's service valve. When the bottle is empty, close that service valve and open the service valve of the other bottle.

With the automatic changeover valve, open the Service valves on both bottles. The bottle to which the arrow in the changeover knob points is the one in service. As long as

there is fuel in the bottle, the FULL-EMPTY indicator on top of the regulator will show white. When the bottle is empty, the automatic regulator will begin using fuel from the "reserve" bottle. When this happens, the FULL-EMPTY indicator will change from white to red.

At this point, the empty bottle should be shut off and the indicator knob turned so that the arrow points to the bottle in service. The FULL-EMPTY indicator again will show white. The empty bottle may now be disconnected for refilling.

Check the indicator flag regularly to avoid running completely out of fuel. You can also check the volume of LP gas by weighing the bottle, comparing the known weight of an empty and a filled bottle. The TARE (empty) weight is stamped on the LP gas bottle handle.

LP GAS REGULATOR FREEZE-UPS

LP gas regulator freeze-up is a problem RV owners can prevent if they are aware of its causes. Although every precaution is taken by fuel producers, tank manufacturer's, and LP gas dealers to keep moisture out of the fuel, this problem at times does exist and causes regular freeze-ups. Suggestions that you may want to follow to help prevent this moisture are:

1. Always keep the main tank valve closed during periods that gas is not in use, especially if the tank is empty; and
2. Contact your LP gas dealer about the addition of anhydrous methanol to your tank. Your dealer may do this for a minimal charge, and it will help to prevent freeze-up.

FILLING LP GAS TANKS

Follow these basic practices to ensure safety.

1. Do not fill your tank beyond the legal liquid level capacity.
2. Never use a wrench or pliers to close the POL valve or liquid level on your tank. These valves are designed to be closed leak-tight by hand. If wrenches are necessary to stop a leak, the valve should be replaced.
3. Use a proper wrench or pliers to tighten the left-hand thread POL nut on the SERVICE valve. Do not over tighten it or jam it. This is a machined brass fitting that seats securely against a female seat in the POL valve; it requires no pipe joint compound.
4. Open the POL valve all the way and then close it one quarter turn. This should be done when you are ready to use your tank. This will assist you in determining if the valve is opened or closed.
5. Make periodic checks for leaks in all tank and line connections. Use a propane gas leak detector solution to make these checks. Vibrations during travel may cause leaks.
6. Be sure to fasten your tank(s) securely in place.

APPLIANCES AND ACCESSORIES

7. Turn the dual tanks so that the open part of the tank guard is facing the trailer. This will protect the valve and regulator from flying rocks or mud.
8. Transport your tank in the same position as it is used normally. Make sure the valve is closed. Do this whether you remove your tank for transport to a dealer or for a refill. Always secure the tank to keep it from falling or rolling.
9. Practice safety at all times. LP gas can be dangerous. If you have any questions about the operation of your gas appliances or the LP gas system, contact your local LP gas dealer.

Note: If your unit is equipped with a horizontal LP gas tank, the tank must be filled in that position.

WARNING!

A warning label has been located near the LP gas container. This label reads:

DO NOT FILL CONTAINER(S) TO MORE THAN 80% OF CAPACITY. Over-filling the LP gas container can result in an uncontrolled gas flow which can cause fire or explosion. A properly filled container will contain approximately 80% of its volume as liquid LP gas. If the tank is over-filled, have the LP gas dealer bleed out the excess. **DO NOT** smoke, strike a match, or ignite a lighter when the LP gas container is being filled. A spark or flame could ignite fumes. Be certain all burner and pilot flames are out and Service Valve is closed when filling your vehicle's LP gas or fuel tanks.

LP GAS LINE CHECK

Regular maintenance of the LP gas system is extremely important to insure the systems safety. All checks and/or repairs should be performed by an authorized service agency who is trained in dealing with RV LP gas systems. **DO NOT ATTEMPT** repairs yourself. The system should be checked at least once every 30 days of use or 5,000 miles of travel. If you are using your vehicle in rough terrain situations or traveling over rough roads these inspections should be done more frequently.

If you check connections for leaks yourself **DO NOT USE OPEN FLAME OR MATCHES TO CHECK LP GAS LINE CONNECTIONS.** Use only an approved leak detector solution. **DO NOT USE** products that contain ammonia or chlorine (most common household soaps). If you detect a leak, shut off the gas and contact either your dealer or the nearest authorized LP gas dealer to have repairs made.

WARNING!

DO NOT MODIFY YOUR LP GAS SYSTEM. DO NOT REMOVE COMPONENTS OR REPLACE WITH COMPONENTS THAT ARE NOT OF EQUAL VALUE. Failure to follow this warning will void any vehicle warranty. Failure to follow this warning can result in explosion or fire which may cause injury or death.

RANGE, RANGE HOOD, OVEN

Your recreational vehicle has a three burner range; it may have an oven beneath the range, and it may have a gravity range hood with a light, a power range hood with fan and light, or a range hood with fan only. The range burners and oven are LP gas appliances. Read the range manufacturer's manual carefully for complete details on the operation and care of the range, range hood and oven.

WARNING!

IT IS NOT SAFE TO USE COOKING APPLIANCES FOR COMFORT HEATING. Cooking appliances need fresh air for safe operation. Before operation:

1. Open overhead vent or turn on exhaust fan.
2. Open window.

This warning is to remind you to provide an adequate supply of fresh air for combustion. Unlike homes, the amount of oxygen supply is limited due to the size of the recreational vehicle. Proper ventilation when using the cooking appliance(s) will avoid dangers of asphyxiation. It is especially important that cooking appliances not be used for comfort heating as the danger of asphyxiation is greater when the appliance is used for long periods of time.

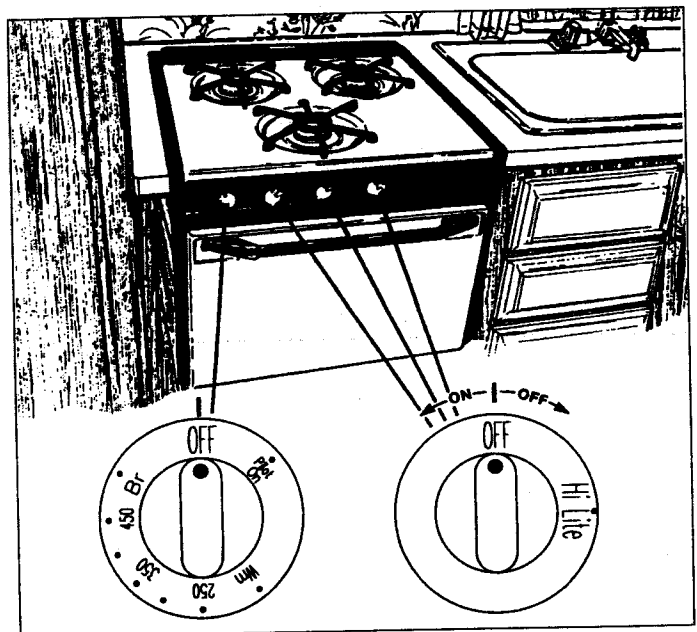

RANGE TOP—3 BURNER

LIGHTING THE PILOT

Note: The oven control knob must be in the **PILOTS ON** position for the pilot to be lit. Once lighted, the pilot will continue to burn.

To light the oven pilot, be certain the LP gas container Service valve is OPEN, then depress and turn the oven control knob to PILOTS ON. Open the oven door and hold a lighted match next to the constant pilot area (it is near the rear of the oven compartment, just below the main oven burner). Relight the pilot if air in the line extinguishes the flame. When the pilot remains lit, adjust the oven control knob to the desired temperature.

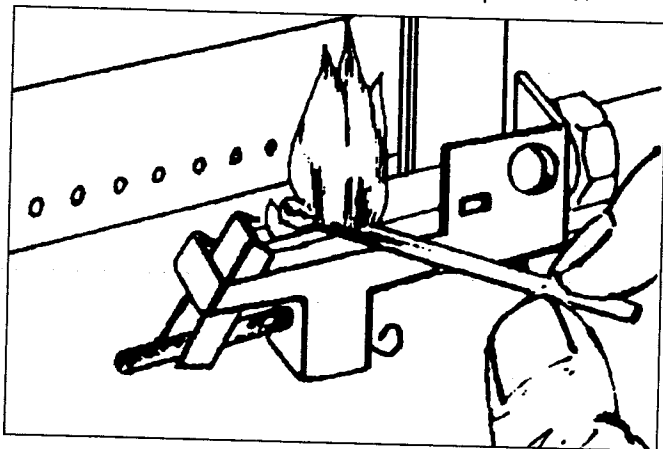

LIGHTING THE OVEN PILOT

LIGHTING THE RANGE

Be certain that the LP gas Service valve is OPEN. Light a match and hold it close to the range burner making sure you are lighting the valve you turned on. Turn the burner's control knob to full ON. Air in the line may cause a blowing noise and may extinguish the match. When the line is free of air, the burner will light readily. Adjust the burner flame with the control knob.

BROILER

Your oven is equipped with a broiler. To use it, light the oven and set the control knob to BROIL. Place the broiler pan (optional equipment) in the area below the oven burner. Do not place meat too close to the flame; grease or fat may ignite. Use foil only as recommended. Never cover the holes in the broiler pan or the air openings in the oven bottom with foil. Always remove the broiler pan as soon as you have finished broiling. If the pan is not removed and the oven is used, the grease may bake onto the surfaces or the grease may ignite.

CARE OF RANGE AND OVEN

Allow the range top to cool, then clean it with hot, soapy water. Use a damp cloth to clean chrome surfaces. Grease splatters, which may bake onto the surfaces, should be wiped off before they have time to harden. Use chrome polish to remove stubborn stains.

Clean the oven with commercial cleaner after each trip, or as necessary. DO NOT apply cleaner to aluminum gas tubing, thermostat sensing bulb or electrical components.

MICROWAVE OVEN

The microwave oven is a 120-volt appliance used to cook, defrost or simmer foods in less time than other cooking methods. Several types of microwave ovens are installed by the manufacturer. Be certain to read carefully the oven manufacturer's owner's manual for specific instructions for the model which may be installed in your unit.

WATER HEATER

Your water heater is an LP gas appliance capable of heating gallons of water to a preset temperature. When the system is connected to city water, fill the water heater by opening a hot water faucet. When filling the fresh water tank, turn the water pump ON and open a hot water faucet. In either case, when water flows steadily, turn the faucet OFF.

WATER HEATER BY-PASS

There is a water heater by-pass system installed in the water lines at the back of the water heater. This by-pass system allows you to use the water system without the water heater, as well as winterize the water system without having to fill the water heater with anti-freeze. For normal operation, close the center valve and open the outside valves. To by-pass the water heater, open the center valve and close the outside valves.

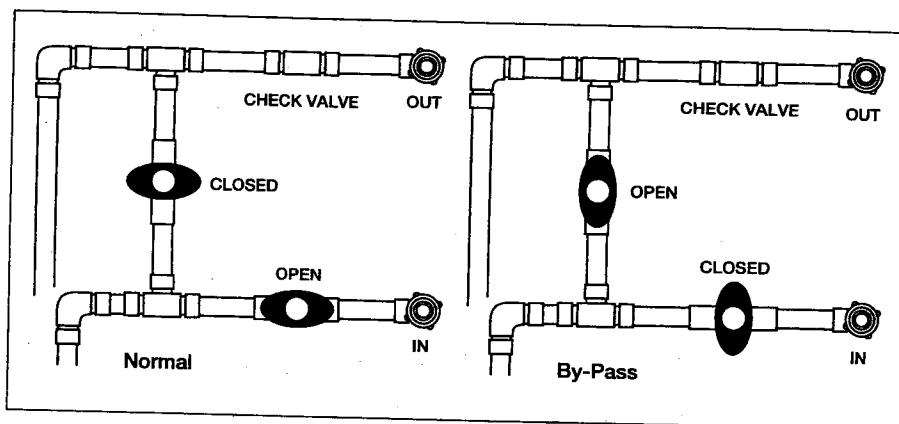

WATER HEATER BY-PASS (TYPICAL)

ELECTRONIC IGNITION

Place the remote water heater switch in the ON position. This switch is located in the lower right corner of the display panel. If the red fault light comes on, place the switch in OFF position and wait 5 minutes. The red fault light will only come on in the event of water heater malfunction or if the flame fails to light. After the required delay, again place switch in ON position. If the water heater turns on a green light will show on the display panel. It may take more than one start attempt when the water heater is being used for the first time or after the LP gas bottle has been refilled. To turn the water heater completely off place the switch in OFF position.

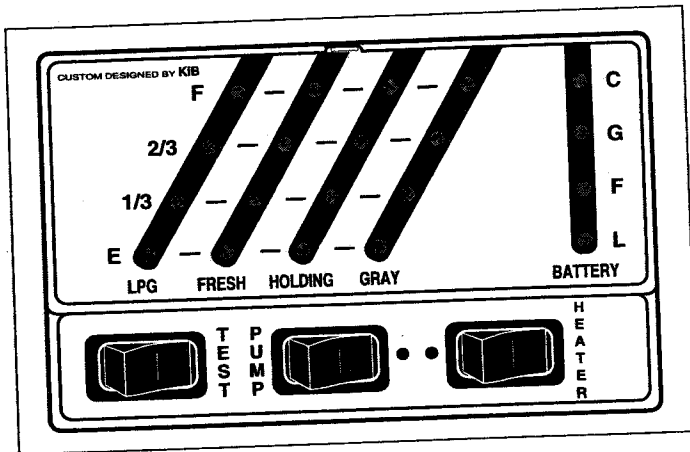

REMOTE WATER HEATER SWITCH

BURNER ADJUSTMENT

Refer to Water Heater Operation Manual.

DRAINING

The water heater has a drain plug or drain cock in the water heater which must be opened or removed to drain the water heater tank. To facilitate drainage, open all hot water faucets. When water ceases to drain, replace plug. Because of the location of the drain plug, about two quarts of water will remain in the bottom of the tank. This can be flushed as described in CARE OF WATER HEATER (listed following CAUTION).

* CAUTION *

Hydrogen gas can be produced in a hot water system served by a heater that has not been used for a long period of time (generally two weeks or more). HYDROGEN GAS IS EXTREMELY FLAMMABLE. To reduce the risk of injury under these conditions, it is recommended that the hot water faucet be opened for several minutes at the kitchen sink before using any electrical appliance. If hydrogen is present, there should be an unusual sound such as air escaping through the pipe as the water begins to flow. There should be no smoking or open flame near the faucet at the time it is open. Contact your dealer or the Coachmen Service Department at the address on the manufacturer's warranty if you are not certain of what action you should take.

CARE OF WATER HEATER

Be certain the exterior compartment is clean and does not contain combustible materials. Never obstruct the relief valve or exhaust vent. Periodically drain and flush the water heater tank.

To flush the tank, connect a hose to the city water fill. Remove the drain plug from the water heater tank. Run water for several minutes to flush tank. Turn water off and reinstall drain plug.

FURNACE

The furnace is an automatic ignition type, controlled by a wall thermostat. Heat is delivered through a duct system.

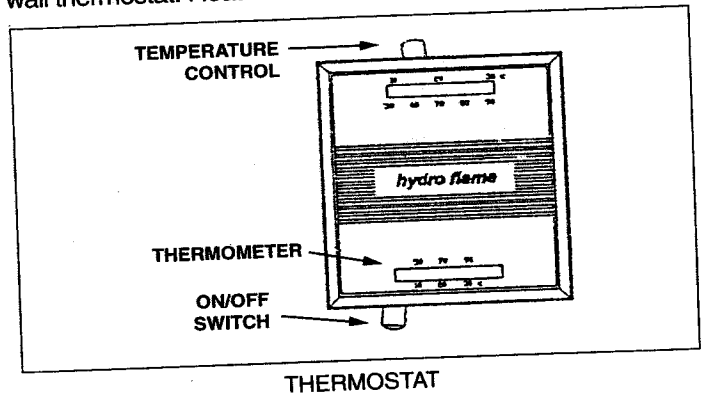

Note: Although the furnace's fuel source is LP gas, the power operates on 12-volt electricity. The furnace requires a minimum of 9 volts to operate.

* CAUTION *

DO NOT use portable fuel-burning heating appliances, including kerosene heaters, wood and charcoal grills and stoves, in your motorhome. Such appliances produce excessive moisture, consume oxygen and may emit dangerous products of combustion.

IGNITION

Before lighting a furnace, be sure the LP gas bottle Service valve is OPEN and the thermostat ON/OFF switch is ON.

AUTOMATIC MODELS

Set thermostat to desired temperature and turn ON/OFF switch to ON. An automatic relay in your furnace provides a time delay. Therefore, when you turn up the thermostat there will be a pause prior to startup of the blower. At blower startup, your furnace air will enter your living quarters at room temperature.

Your furnace will start warming quickly and continue getting warmer for the next several minutes. If your motorhome is cold throughout, it may take from one to several hours to heat all interior walls, ceilings, floors and fixtures to a comfortable temperature. Once reached, your furnace will automatically maintain steady warmth.

On initial lighting, the burner may not ignite due to air in the gas lines. If this occurs, set the thermostat back to the lowest setting and wait 30 seconds; then reset thermostat to the desired temperature.

*** CAUTION ***

If the furnace does not light after several attempts, while allowing each time for any delay pause, turn the thermostat OFF and contact your authorized Coachmen dealer or service center. DO NOT attempt to repair or adjust the furnace yourself.

When changing your unit's electrical source, as from 12-volt to shoreline or generator, turn the thermostat off. This will preserve the life of your furnace's electronic system. Carefully read the furnace manufacturer's manual for other important Do's and Don't's of service and operation.

PREVENTIVE MAINTENANCE

Preventative maintenance should be performed annually by an authorized dealer and should include cleaning of heat exchanger, furnace ducts and blower wheels to remove dust, lint and other foreign materials. The furnace's LP gas system should also be checked. Check manufacturer's manual for further information.

REFRIGERATOR

Your refrigerator is two-way (LP gas and 120-volt electricity). It is equipped with a control system, which can automatically select the most suitable energy source which is available, either 120-volt AC, or LP gas operation. The refrigerator can be run either in a factory preset temperature setting AUTO mode, or in MANUAL mode.

NOTE: Under certain cool weather conditions the food in the lower portion of the fresh food compartment may freeze if operated for extended period of time in the MANUAL mode.

The refrigerator controls will work down to 9.6-volt DC.

WARNING

Most LP gas appliances used in recreational vehicles are vented to the outside of the vehicle. When parked close to a gasoline pump, it is possible that the gasoline fumes could enter this type of appliance and ignite from the burner flame, CAUSING A FIRE OR AN EXPLOSION.

FOR YOUR SAFETY, it is recommended that all LP gas appliances which are vented to the outside should be shut off when refueling.

It comes with operational instructions and most have instructions posted near the controls. Ask your Coachmen dealer to demonstrate the operation of the refrigerator in your RV. The instructions given here are for your convenience; in case of a difference, use the instructions furnished with your refrigerator.

The refrigerator operates on the gravity flow of chemicals, so it must be level. If you must stop on an uneven site for more than 30 minutes, turn the refrigerator OFF. Use a level in the freezer compartment to check levelness.

Before starting on a trip, use the shoreline connection to cool the refrigerator the night before departing. Keep items to be stored in the RV refrigerator in your home refrigerator or freezer until you are ready to leave. This will reduce the cooling load on your refrigerator and help keep perishable foods fresh longer. Always store food in sealable containers or suitable wrapping. When traveling, switch to LP gas operation. Use door lock during travel.

*** CAUTION ***

Some states and municipalities do not allow operation of LP gas systems while the vehicle is in motion. If you have a question in this regard, check with local law enforcement authorities.

START UP INSTRUCTIONS

- A. A continuous 12-volt DC supply must be available for the electronic control to function.
- B. Press the main power ON/OFF button to the DOWN position.
- C. In AUTO mode operation, the temperature is automatically controlled by a factory preset temperature setting, on the energy source selected by the control system.
- D. In MANUAL mode operation, the refrigerator will run continuously on the energy source selected by the control system.

NOTE: Under certain cool weather conditions the food in the lower portion of the fresh food compartment may freeze if operated for extended period of time on this mode.

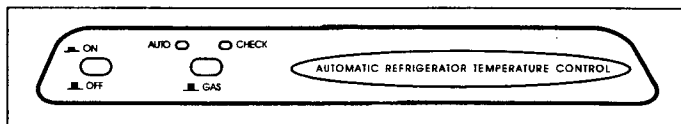

REFRIGERATOR CONTROL PANEL

AUTO MODE

1. Press the AUTO/MANUAL mode selector button to the DOWN position. The AUTO mode indicator lamp will illuminate. If 120-volts AC is available, the control system will select AC operation. If 120-volts AC is not available, the control system will automatically switch to GAS operation. Within 45 seconds the burner should be ignited and operating normally.
2. If the CHECK indicator lamp illuminates, the control has failed to ignite the burner on GAS. To reset when the CHECK indicator lamp is illuminated, press the main power ON/OFF button to the OFF then ON position.

- On the initial refrigerator start-up on gas (120-volts AC is not available), it may take longer than 45 seconds to allow air to be purged from the gas line. If the refrigerator has not been used for a long time or the LP tanks have just been refilled, air may be trapped in the supply lines. To purge the air from the lines may require resetting the main power ON/OFF button three or four times. If repeated attempts fail to start the LP gas operation, check to make sure that the LP gas supply tanks are not empty and all manual shutoff valves in the lines are open. If the problem is still not corrected, contact a service center for assistance.

NOTE: Do not continue to reset GAS operation if the CHECK indicator lamp continues to be illuminated after several tries.

- In AUTO mode operation, the temperature is automatically controlled by the factory preset temperature setting.

MANUAL MODE

- Move the AUTO/MANUAL mode selector button to the UP position. The AUTO mode indicator lamp will go off.

The difference from AUTO mode is that in MANUAL mode operation, the refrigerator will run continuously on the energy source selected by the control system.

NOTE: Under certain cool weather conditions the food in the lower portion of the fresh food compartment may freeze if operated for extended period of time on this mode.

TO SHUT OFF THE REFRIGERATOR

The refrigerator may be shut off while in any mode of operation by pressing the main power ON/OFF button to the UP (OFF) position. This shuts off all DC power to the control system.

NOTE: To avoid running out of battery the climate control should be turned OFF.

The interior light should be turned off during defrosting and storage periods, use a tape to close the light switch or remove the lamp bulb.

CARE OF REFRIGERATOR

Remove food and ice after each trip. Clean the interior of the refrigerator with a lukewarm, mild baking soda solution. The evaporator, ice trays and shelves must, however, be cleaned with warm water only. Wipe dry with a soft, dry cloth. Never use strong chemicals or abrasives to clean the refrigerator; they can do harm to the plastic and aluminum surfaces. If the refrigerator is not in use for a period of time, turn all power OFF, empty and clean the interior and leave the door slightly ajar.

To defrost refrigerator freezer, remove food and ice. Turn the thermostat OFF. To speed up the defrosting process, fill the ice trays with hot water. When all frost is melted, empty the drip tray and dry the interior of the refrigerator with a clean cloth. Replace the drip tray and ice trays, replace all food stuffs and set the thermostat at

MAX for a few hours. Later, reset the thermostat knob to its normal position.

OPTIONAL REFRIGERATOR w/ICE MAKER

Your RV may have an optional refrigerator with a built-in automatic ice maker. Please refer to manufacturer's owner's manual for care and operating instructions.

WASHER/DRYER

Some of the Coachmen models offer a washer/dryer package. Several types of washer/dryers may be installed in your unit. Be certain to read carefully the manufacturer's owner's manual for specific instructions for the model which may be installed in your unit. Please read the section about the second power source before trying to operate.

ROOF AIR CONDITIONERS

If you did not order the optional roof air conditioner at the time of purchase, your RV is wired so that one (or two) can be installed later. The roof air conditioner will operate only on 120-volt electricity.

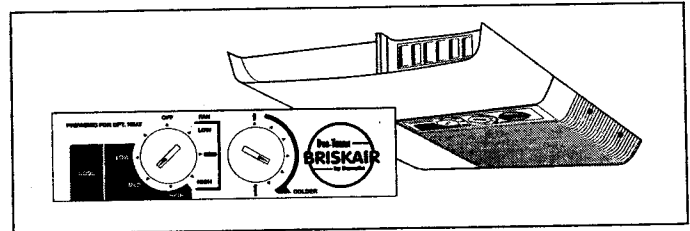

ROOF AIR CONDITIONER—TYPICAL

More than one type of roof air conditioner is installed at the factory. Consult your Coachmen dealer and your roof air conditioner manufacturer's manual for specific instructions for the one installed in your RV.

Before starting any model of roof air conditioner, close all doors and windows. The controls for the air conditioner are on a panel on the portion of the appliance that is attached to the ceiling inside your unit. You can select cooling, fan only, or—with the optional heat package—heating.

AIR CIRCULATING ONLY/COOLING

Turn the Selector switch to COOLING, then rotate the thermostat to the position that is most comfortable to you and adjust the directional louvers to the desired direction of air flow. The compressor will cycle on and off, automatically maintaining the temperature you've set.

HEAT

The optional heat unit on some models is not a substitute for a primary heating system. It is designed to warm the air during moderately cool days or nights. If your air conditioner is equipped with the optional heat package, turn the selector switch to HEAT and rotate the thermostat to the position most comfortable and adjust the directional louvers to the desired direction of air flow. The heater will cycle on and off automatically to maintain the temperature.

DUCTED ROOF AIR CONDITIONING

The ducted roof air conditioning system is optional on most travel trailers and fifth wheels. It utilizes ducts in the ceiling to distribute the air flow throughout your recreational vehicle. The air flow can be regulated by opening and or closing the outlets of your choice. The thermostat for the ducted A/C system also controls the furnace. It is necessary to move the switch to the desired function, ie. . . . heat or cool.

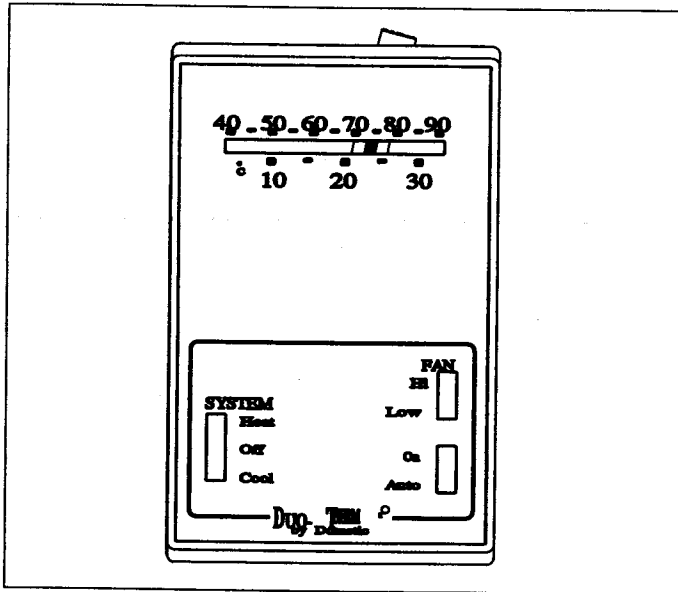

ROOF AIR CONDITIONER—TYPICAL

AM/FM RADIO AND/OR CASSETTE TAPE PLAYER

For optimum performance, clean the tape head as often as necessary, depending on frequency of use. The tape head on most models can be cleaned with a special cleaning cassette cartridge; others can be cleaned with isopropyl alcohol on a cotton swab. Keep cassette tapes away from magnetized objects and follow manufacturer's recommendations for tape types and length. For specific operating instructions, cleaning, tuning and helpful hints, read your radio/tape player manufacturer's manual.

SATELLITE RECEIVER

To operate the satellite receiver there must be a clear skyward view to the South. Turn on the television and turn it to channel 3 (make sure the booster is turned off and switched to cable). Determine which direction is North. Move the rotation clamp of the satellite dish to the "LOCK" position (0 degrees). Turn the directional dial until the arrow is pointing North. Unsnap the elevation crank and turn clockwise in the direction of the "UP" arrow, about 14-15 turns or until resistance is met. Turn the receiver on and access the installation menu to determine the antenna azimuth (direction/heading) and antenna elevation. This is done by determining your surrounding zip code. For example: if you are in LaGrange County and the surrounding zip code is 46761, you would enter 46761 in the receiver menu. After entering the zip code, the menu

screen will provide you with the proper settings. Move the rotation clamp to the "ROTATE" position. Turn the directional handle until the pointer on the handle is pointing in the direction indicated by the receiver. Turn the elevation crank counter-clockwise to get the elevation shown by the receiver. One full turn equals approximately 7 degrees of elevation angle. The receiver should indicate if it is receiving a signal. Fine tune the antenna by moving it slowly to the left, then right until you are receiving the highest signal strength. Place the rotation clamp in the "LOCK" position. Slowly raise and lower the antenna until you have peaked the signal. To lower the dish, set the rotation clamp to the "ROTATE" position. Rotate the dish until the pointer on the directional handle aligns with the rotation clamp. Turn the elevating crank counter-clockwise in the direction of "DOWN" or until resistance is met. Move the rotation clamp to the "LOCK" position. Snap the elevation crank into place. The dish is now locked in the travel position.

TV ANTENNA/CABLE SYSTEM

This system allows you the flexibility to use the amplified TV antenna hook up, or cable, if your location has cable hook ups. To use the TV antenna, simply turn on the power supply switch at the wall plate. To use the cable, turn the power switch off at the wall plate.

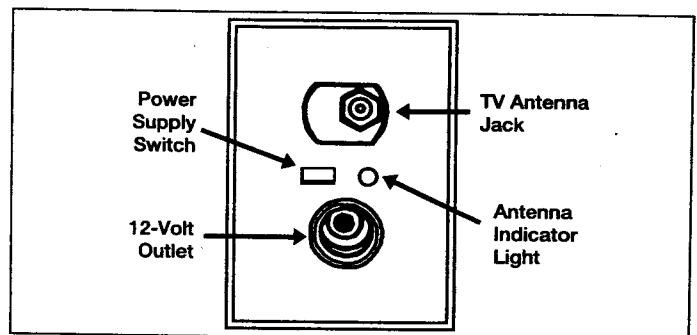

TV WALL PLATE

To raise the antenna, turn the antenna control handle in the up direction until some resistance is felt. Pull down the rotating knob to disengage it from the ceiling plate and turn it until you find the best sound and signal.

Always lower the antenna before moving your recreational vehicle. Pull down and turn the rotating portion so that the pointer lines up with the ceiling plate pointer. Turn control handle in down direction until some resistance is felt. Turn off the power switch on the wall plate.

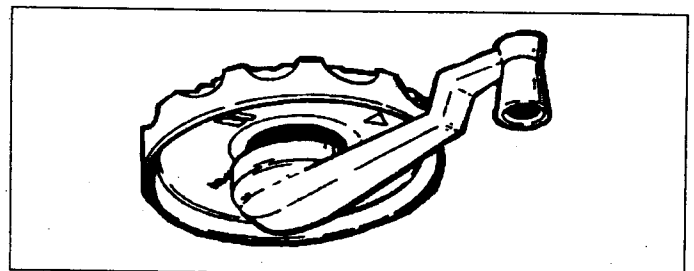

TV ANTENNA CONTROL

Most wall plates also have a 12-volt receptacle for TV sets designed to run on 12-volt DC power. This receptacle should not be used for high current devices

such as 12-volt hair dryers, as the maximum amp draw should not exceed 7.5 amps.

Note: Even though your 12-volt radio and/or TV antenna will operate on the 12-volt current that is supplied through the power converter, spikes and surges in the current are possible and will result in poor reception. It is recommended, therefore, that these items be used only in conjunction with a properly installed RV battery.

TELEVISION

The optional color TV(s) installed in some models are placed in a convenient location designed to give you optimum usage. Refer to manufacturer's instructions for further information regarding tuning, care, etc.

CABLE TV AND PHONE JACK

This option enables you to receive cable TV. The phone jack is usually in the living area for convenience and accessibility. The outside portion of your phone jack needs only a direct feed line snapped into it for phone service to begin.

The cable TV package includes an outside receptacle to hook up your cable feed.

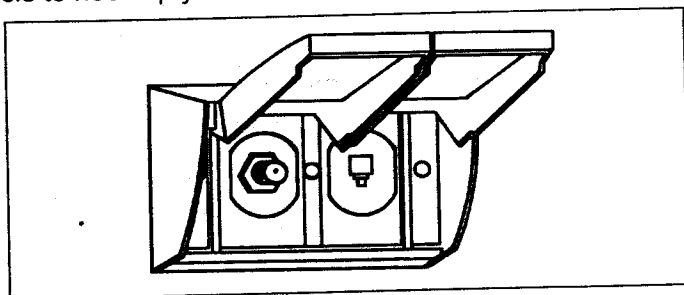

EXTERNAL CABLE TV & PHONE JACK

STORAGE

You should follow these procedures if you will not be using your unit for an extended period.

LP GAS

Close the LP gas container's Service valve. Extinguish all pilots and close all appliance LP gas valves (oven/range, water heater, refrigerator, furnace). Light a range burner to consume any gas remaining in the lines. When the flame burns out, turn the range burner off.

WATER HEATER

Drain the water heater. To drain, see Water Heater Draining in the APPLIANCE section of this manual.

WATER TANK

To drain the water tank, switch the water pump on and open all faucets. Open the tank's drain valve (Figure 4, Page 54). Open all hot and cold water line drain valves. When the tank is empty, close all faucets and drain valves.

WATER PUMP

When the water tank and water lines have been drained, remove the outlet hose from the pump. Turn the pump on, allowing it to pump out any remaining water, usually about a cupful. Use a towel or cloth to catch this water. Reattach the outlet hose.

ELECTRICAL SYSTEM

Turn off all circuit breakers at the Power Center. Disconnect all loads from the battery. Make sure battery is fully charged.

GENERAL

Close and secure all doors and windows. Open a roof vent or window slightly to allow circulation, but not so far that rain or snow can enter.

WINTERIZATION

Make special preparations for storing your unit in cold winter climates. All systems and components should be inspected and, if necessary, repaired prior to storage. Winterize the UNIT before removing the RV battery.

Note: If you will be using your RV during cold weather, be certain to keep the fresh water system drained or use an **approved, non-toxic RV antifreeze** to prevent freeze-ups. Have an LP gas supplier add methanol to your LP gas containers. Consult your authorized Coachmen dealer for more information.

Refrigerator. Remove all food from the refrigerator, defrost and wash and dry the inside. Prop the door open so air can circulate.

Cabinets. Check the staple foods in your cupboards and remove any that could freeze and be damaged. Leave cabinet and closet doors open a little to prevent a musty odor or mildew.

Holding Tanks. The dump valve shafts should be inspected and lubricated. Be certain the dump valves are closed.

Fresh Water System. Drain as described in the **STORAGE** section of this manual, then pour two gallons of non-toxic RV anti-freeze into the gravity water fill. Turn shut off valves at the water heater to the winterize position. (If you wish to put anti-freeze in the water heater, use six gallons of RV anti-freeze and leave the shut off valves in the normal position). See diagram under water heater by pass in **APPLIANCE** section of this manual. Winterize the fresh water system by briefly opening all water faucets and switching the water pump on. Close faucets when anti-freeze flows out. Switch pump off. Pour anti-freeze (non-toxic) into sinks and shower/tub. Enough to fill P-traps.

*** CAUTION ***

Do not use automotive antifreeze in the water or sewage system. It is poisonous and also corrosive to sewage system components.

Water Heater. Drain the water heater (see water heater draining in APPLIANCE SECTION). Although about two quarts of water will remain after the heater has been drained, there is ample room for expansion if it freezes.

Water Tank. Drain by switching the water pump on and opening all faucets. Open the tank's drain valve. Open all hot and cold water line drain valves. When the tank is empty, close all faucets and drain valves.

Water Pump. The water pump should be drained when the water tank and water lines have been drained. Remove the outlet hose from the pump. Turn pump on, allowing it to pump out any remaining water, usually about a cupful. Use a towel or other cloth to catch this water. You can re-attach the outlet hose now or later.

Toilet. Flush toilet until antifreeze is present in the bowl. Pour one gallon of approved, non-toxic RV antifreeze down the toilet to winterize the waste water holding tank. The toilet water supply line should be drained completely and the water supply valve should be left open. On models with pedals, this can be done by inserting a round object, like a soft drink bottle, into the flush hole in the bowl. On models with the black/white levers, block the white lever in the open position with a wad of paper. When using air pressure to drain the water line, toilet valve should be held in the open position. If water is inadvertently frozen in the toilet, do not flush until the ice is thawed.

LP Gas Regulator. Cover to keep moisture out of vent. LP gas system should be prepared as described in STORAGE section. Containers should have anhydrous methanol added by an LP gas supplier.

RV Battery. Recharge and add water, if necessary. Disconnect the battery cables and store battery in a cool, dry place. Check regularly and recharge as needed. Do not store battery in an area where possible exposure to extreme heat or sparks can occur. Be sure room is properly ventilated to dispel hydrogen fumes given off by battery.

Windows. Cover with newspaper or cardboard to protect fabrics from fading.

Exterior Vents. Cover range hood, refrigerator and furnace vents with plastic. Inspect all roof vents and replace, if necessary.

*** CAUTION ***

Never use appliances with vent covers in place.

Exterior. Clean and wax, lubricate locks and hinges. Check under the motorhome for any openings which would allow varmints to enter; seal if necessary. Lock

securely. Inspect throughout the winter months and remove any snow accumulation from the roof with a long-handled broom or similar tool.

FIRE SAFETY

Prevention is the best form of fire safety. Observe the same precautions in your RV as you do in your home.

Use care with any open flame inside of your unit. Follow the instructions previously listed for the care and maintenance, and operation of the various appliances in your RV.

Make certain everyone in your party is familiar with the emergency features of the unit, the location of exits and the location and operation of fire extinguishers. "It is recommended that a fire drill be conducted on a regular basis to ensure this knowledge." A chemical fire extinguisher has been furnished with your unit. Check it regularly to be sure it is ready for emergency use. Immediately replace a fire extinguisher that is discharged or partially discharged. Fire extinguishers are located directly inside the front entrance door on either a cabinet or on the sidewall.

*** CAUTION ***

Do not bring or store LP gas containers, gasoline or other flammable liquids inside your RV.

SMOKE DETECTOR

Your RV has a smoke detector. Test it after the vehicle has been in storage, before each trip, and at least once a week during the time you actually use your RV.

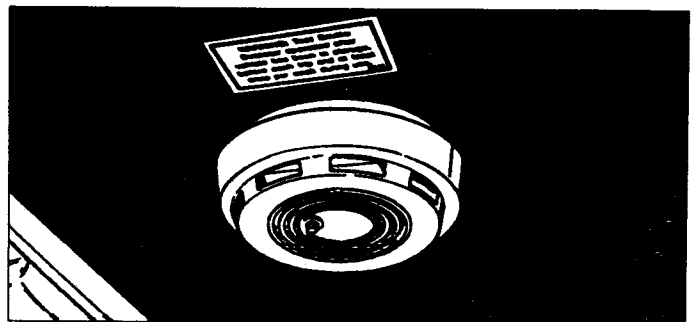

SMOKE DETECTOR

EMERGENCY EXITS

Emergency exits are installed in some models. These will be marked by a label which has one-inch red letters. Handles that must be operated to open emergency exits also will be colored red. Make certain your dealer explains the location and operation of emergency exits to you, and that you inform all members of your party.

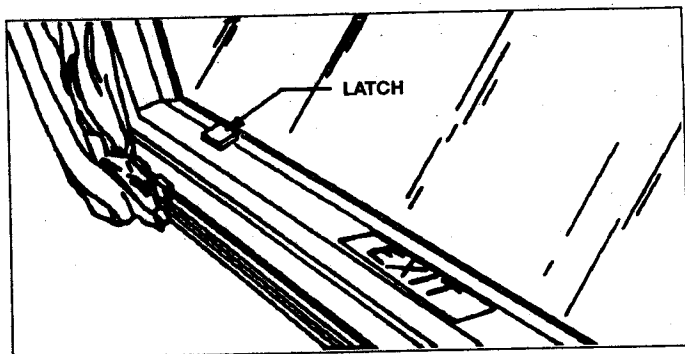

EMERGENCY EXIT WINDOW

RV MAINTENANCE

RV owners are noted for the pride they take in the appearance of their units. Proper maintenance will do more than keep your trailer looking nice. It can help ensure trouble-free operation and maximum efficiency of the appliances and accessories. Failure to maintain the vehicle or its components may also constitute a breach of your warranty obligations. Just as an open window or an unrepaired leak in your home may lead to costly damage, the failure to repair leaks in your vehicle or to reseal your seams may result in serious damage to your motorhome. Read the various appliance and component manufacturer's manuals for specific maintenance information.

Unless otherwise noted, maintenance functions should be performed at least annually. All maintenance schedules listed are the minimum requirement; heavy use, unusual temperatures or humidity, or other environmental conditions may require more frequent maintenance. At the start of each season, or after a period of storage, thoroughly inspect and test all systems and components to be certain they are functioning properly before you use your motorhome.

Airing of the unit is essential before you occupy it. See details under the **AIR QUALITY** and **CONDENSATION** sections of this manual.

Awning Supports and bright metal parts should be cleaned and coated with silicone annually.

Axle and Suspension should be inspected frequently; paint and adjust as necessary.

Batteries should be inspected frequently and refilled or recharged as necessary; battery cables and terminals should be checked and cleaned every 90 days.

Body should be washed to remove dirt, dust, road tar, bird and tree droppings, insects, and other foreign material from exterior surfaces. Use a mild soap in lukewarm water. Apply an automotive-type wax at least once a year.

Brakes should be inspected every six months and replaced as necessary. (See also **APPENDIX C: TRAILER BRAKES** in this manual.)

Bumper and Frames that are painted, or any exposed painted surface, should be inspected for damage and rust. Rust should be removed and bumper and frame painted with rust preventive paint annually.

Counter and Table Tops should be cleaned periodically with a mild detergent and polished with a product such as **Pride** or **Pledge**.

Cushions, Chairs, Sofas may be labeled with the voluntary industry cleanability code. Because dyes or backings on some upholstery fabrics will be affected by water or solvents, the cleanability code will indicate the cleaning method that is safe for your fabric. If the furniture is not coded, test the fabric for discoloration on an inconspicuous part of the furniture before spot-cleaning. The code is symbolized by the following letter:

W

Use only water-based cleaning agents or foam. Mix two tablespoons ammonia or detergent, such as **Ajax** liquid, with a quart of water. Wipe the stain gently with a clean cloth dampened with the solution. Continue wiping, turning the cloth so that you are always using a clean portion, until the stain is removed. Be careful not to wet the fabric too much. Always wipe from the outer edge of the stain toward the center.

S

Use only mild, pure, water-free dry-cleaning solvents, such as **Energine** or **Carbona**. Dampen a clean cloth with the solvent and follow the same procedure described under **W**.

WS

Either of the above methods may be used.

X

Clean fabric only by vacuuming or light brushing to remove soil. Do not use liquid cleaning agents of any kind.

TYPES OF STAINS

Water-Based—ketchup, soft drinks, milk, etc. Remove using method **W**.

Oil-Based—salad dressing, butter, greasy food, etc. Use method **S** or, for flat-woven fabrics, not velvet, apply **Texize K2R Spot Remover** according to directions.

Combination—ice cream, gravy, etc. are both watery and oily. Remove these types of stains using the **S** method and follow with the **W** method.

Mud—lift away what you can easily remove without forcing the mud into the fabric. Allow the remaining mud to dry completely, then vacuum. If the stain remains, clean with method **W**.

When overall cleaning is necessary, professional cleaners are recommended. However, if you wish to do it yourself, follow these suggestions:

1. Vacuum thoroughly.
2. Test fabric for discoloration on an inconspicuous place using a foam cleaner such as **Fibre Fresh Concentrate** or **Glamorene**.
3. If no discoloration appears, use cleaner on entire item. *Note:* Many velvet fabrics cannot be cleaned with water-based cleaning agents.
4. After cleaning, you may wish to apply **Scotch-guard** fabric protector to such areas as furniture arms, backs and cushions.

Note: The above information is provided only as a service and should not be interpreted as a warranty. The list of cleaning agents does not constitute an endorsement of products; other similar products may be equally effective.

Draperies, Curtains, Bedspreads should be dry-cleaned only.

Electrical System should be inspected and tested prior to each trip. Check the shoreline for damage. Test the 120-volt system for proper polarity and voltage. You may want to purchase a ground monitor and a line voltage tester to perform these checks.

Fabrics need regular and continuing care. To keep them at their best, vacuum and brush away loose dirt before it becomes embedded and more difficult to remove. Clean spills and stains while fresh. VELVET fabrics should be cleaned with extreme care. Spills on velvet generally will bead-up. Blot them up quickly and gently so as not to force the stain deep into the fabric. If a stain remains, spot-clean using one of the methods described below. Wipe the stain in the direction of the pile to prevent distortion. When the fabric is dry, gently brush with a soft brush. Many velvet fabrics cannot be cleaned with water-based cleaners.

Floor Coverings should be cleaned as necessary. Vacuum carpeting. Avoid using heavy moisture; it could enter and damage your floor.

Parquet Wood Flooring—This optional flooring is located in the kitchen area. **Never damp mop** with water. It will permanently damage the floor. A slightly damp cloth is acceptable to use for spills in small areas. Please refer to owners' packet for maintenance and troubleshooting.

Hinges should be inspected and lubricated with light household oil periodically.

Hitch Ball/Pin (latch, coupler, fifth wheel plate) should be inspected prior to each trip and lubricated every 90 days.

Jacks (manually operated) should be inspected prior to each trip and lubricated every 90 days. Power jacks also should be inspected prior to each trip, but lubrication is required annually. See the instructions provided with the power jack installed on your unit for specific details. Periodically apply a small amount of WD-40 or similar lubricant at friction points of stabilizing jacks.

Locks and Latches should be inspected and lightly lubricated with graphite periodically.

LP Gas system should be inspected and adjusted as outlined in LP Gas section of this manual. Be certain mounting supports for tanks are secure. Before using, be sure all LP gas orifices and vents are clean.

LP Gas Line Check should be performed frequently. Always check the gas line connection after each refill and inspect the connections regularly, at least every 30 days or 5,000 miles of travel. To check, turn off all burners and pilot lights. Open all doors and windows. Open the LP gas tank Service valve and use an approved LP leak detector solution to test all line connections. Bubbles indicate a leak. Do not use products that contain ammonia or chlorine. Tighten the connection with two open end wrenches until bubbles stop. If leak persists, contact your Coachmen dealer.

Lug Nuts should be checked after 10, 25 and 50 miles or whenever a wheel has been reinstalled. If lug nuts continue to loosen, they should be replaced. Be certain to use the proper torque (90 to 120 ft./lbs.). For more information check Chassis owner's manual.

Pigtail Contacts should be inspected and coated with WD-40 every 90 days.

Roof, Body, Underbelly should be inspected for damage, rust or corrosion every 90 days and repaired as necessary.

Rubber Roof

1. Keep your roof clean. Clean your roof four (4) times annually. For normal Cleaning:

- Use a mild laundry detergent. (See caution below).
- Rinse complete roof with clean water to remove any loose dirt or debris.
- Using a medium bristle brush along with your selected cleaner mixed with water, scrub the entire roof. Rinse thoroughly with clean water to avoid residue build up on the roof or side wall of the vehicle.
- For more difficult stains, you may use cleaning materials mentioned above in a more concentrated mixture. For stubborn stains, use of a rag dampened with mineral spirits is recommended. DO NOT use mineral spirits in a large area or allow it to soak into the membrane. Household bleach or windshield washer fluid can also be used (fully concentrated) and allowed to soak in stubborn stain areas, then scrubbed with a medium bristle brush or rag. Rinse thoroughly.



DO NOT use general purpose cleaners containing petroleum solvents, harsh abrasives, or citric based cleaners.

2. Beware of areas where fruit or tree sap or harsh environmental fall out may stay on the roof for an extended period of time. These conditions may result in unremovable stains. If you are in these conditions, you may have to increase the frequency of your cleaning or premature deterioration may occur.

If an accident happens and you damage the roof, here is a temporary fix: Clean the affected area with a rag dampened with mineral spirits and let dry. Cover the area by overlapping layers of duct tape over the troubled area, until a permanent repair can be made by your Coachmen dealer.

Safety Chains should be inspected for damage prior to each trip; replace if weakened.

Seams or Joints should be sealed around the roof, entrance doors, windows, roof and wall vents, access doors, storage compartments, roof edges, luggage racks, ladders, air conditioners, TV antenna, rails and moldings

at least once each year with a similar high-quality sealant. Inspect all seams and joints at least twice a year and reseal as necessary. Some sealants cannot be applied over other types; when preparing areas to be resealed, scrape off old sealant. Clean metal areas with a vinegar and warm water solution. Clean fiberglass areas with mineral spirits before applying new sealant.

Shades, Blinds and Valances should be vacuumed or wiped with a damp cloth.

Sinks in the RV kitchen and bathroom should be cleaned with a cleaner that is non-abrasive. Stainless steel and porcelain cleaner may be purchased at most grocery stores. ABS cleaner may be purchased from your Coachmen dealer.

Step(s) should be inspected annually. Remove rust; paint steps and lubricate all moving parts.

Tires should be checked for damage and proper inflation prior to each trip. Bias-ply tires should be balanced and rotated annually; Radial tires should be balanced as necessary but, if required, these tires should be rotated front-to-rear or rear-to-front only.

TV Antenna exterior moving parts should be lubricated periodically.

Vents should be inspected and cleaned annually; lightly oil all moving parts. Inspect vents periodically for bird nests.

Vinyl-Coated ceiling and wall panels should be cleaned with a mild soap and damp sponge as needed.

Water Heater control compartment should be kept clean and free of combustible material and flammable liquids. The vent and combustible air grille should be clear of any obstructions. Manually operate the pressure temperature relief valve at least once a year. Operate only when storage water in tank is cool. Periodically compare main and pilot burner flame with illustrations in the manufacturer's operation instruction manual. Do not tamper with the pilot orifice to increase the pilot flame size; this can cause high water temperature and failure of gas control.

Wheel Bearings should be cleaned and repacked at least once a year.

Windows, Doors, Compartment Doors should be inspected for damage or leaks prior to each trip. Replace any damaged or worn parts. Fix or replace any leaking parts. Lubricate moving parts and rubber seals with silicone lubricant. Clean dirt and debris from window tracks.

Wood Cabinetry should be protected and cleaned several times a year using any good non-silicone wood polish. Careful control of temperature and humidity will help reduce expansion and shrinkage of doors and door panels. If shrinkage occurs and unfinished parts of the door panels are exposed, cover the exposed areas with matching touchup stain available from your Coachmen dealer.

Appendix A ✓ Pre-Travel Check

GENERAL DRIVING CHECKS

For your safety, make certain that the following items have been checked and rechecked before you take your RV on the road. Make certain that all items inside of your RV are secured (e.g., lawn chairs, pots and pans, TV, etc.). As you travel, these items, if not secured, may become damaged or may damage the interior of your RV.

Front Jacks—The front jacks must be raised as far as possible.

Lights—The following lights should be tested on both the RV and the tow vehicle: brake lights, warning lights, flashers, clearance lights, taillights and headlights. Clean all lens covers.

Pigtail—The pigtail should be connected properly to the tow vehicle's electrical harness.

Hitch Coupler/Pinbox—Inspect the hitch coupler or pinbox to be sure they have not loosened.

Rearview Mirrors—Adjust the rearview mirrors so that the driver can see the right and left sides of the unit.

OTHER DRIVING CHECKS

Whether you are departing from your home, rest area or campsite, you should check the following parts of your RV before you take off.

Tires—Before each trip, check your tires for uneven wear, road damage, foreign objects or excessive peeling or bulging. Each morning, inspect the condition and pressure. Heat generated by surface friction will increase the tire's air pressure approximately six to nine psi; therefore, do not bleed air out of a hot tire. Inflate the tire to the recommended pressure (indicated either on the tire or in the manufacturer's instruction booklet).

Note: Proper tire inflation is extremely important.

A tire should be replaced when:

1. It is worn to 1/16-inch depth in two or more adjacent grooves.

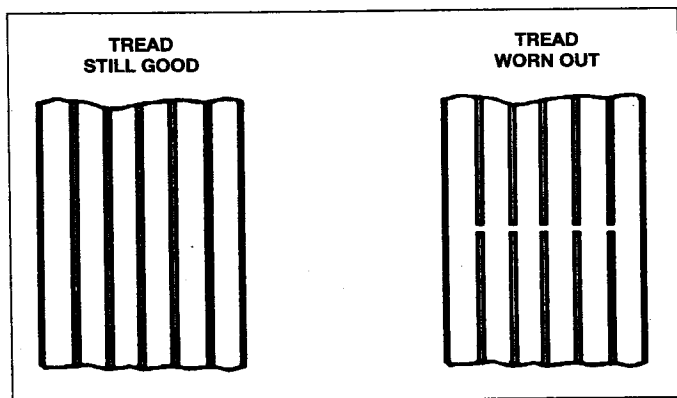

TREAD WEAR INDICATOR

2. It is worn to the level of the tread indicators that are molded into the bottom of the tread grooves, or

3. The indicators appear in two or more adjacent grooves at three locations around the tire.

On new tire purchases, be certain that the new tire is the same size as the old tire and that the new tire has the same ply rating and load range as the old one. DO NOT mix radial-ply tires with bias or bias-belted tires.

Tire Change (in the event of a FLAT or WORN tire)—Turn on tow vehicle's hazard warning flashers. Set up flares or warning lights. Put a chock under the opposite tire and unhitch the unit from the tow vehicle. Place a scissors-type or hydraulic jack on a block of wood directly UNDER THE FRAME close to the tire you intend to change. DO NOT use a bumper jack; it could damage the sidewalls or floor board. Raise the jack to take some of the weight off the tire. Loosen the lug nuts. Raise the jack until the tire clears the ground, then remove the lug nuts. Pull the tire off and put the spare tire on the hub. Replace and tighten lug nuts. Lower the jack until the tire just touches the ground. Tighten the lug nuts to a torque of 90 to 120 ft./lbs. Lower and remove jack. Stop at the nearest service station and have the torque checked and spare tire air pressure checked. You might have to replace the lug nuts after changing tires five times. These nuts could lose their self-locking feature after that many changes.

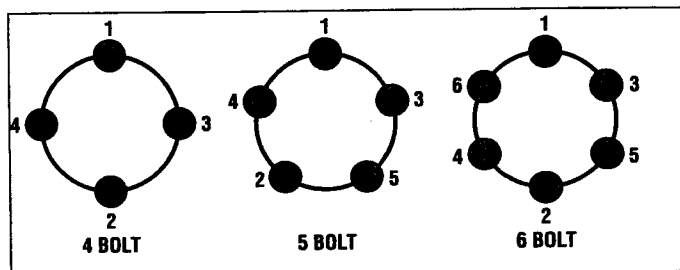

TORQUE SEQUENCE



Never place the jack under a bumper or edge of the sidewall. Use the jack only for changing tires. Never get underneath the vehicle when using the jack; always securely stow the spare tire in the proper area and return all jacking equipment to its proper storage area.

Wheel Lugs—Wheel lugs must be tightened after 10, 25 and 50 miles whenever a wheel has been reinstalled. Thereafter, check lugs after storage.

Power Cord—The 120-volt shoreline power cord must be unplugged from the external source and placed into its compartment. The cord hatch must be secured before you travel.

Water Fill Hose(s)—All hoses must be disconnected and all hose caps must be secured before you travel.

Sewage Termination Valves—These valves must be closed and locked before you travel. The sewer hose must be removed from the termination valve outlet and stored in the appropriate compartment. Termination caps must be securely fastened to the termination valve outlet(s).

Door Step—The door step (Figure 19, Page 55) must be returned to its travel position before the unit is safe for traveling. To do this, lift the front edge of the step and push it under the unit.

Windows and Vents—All windows and vents should be closed completely or adjusted as desired before you travel.

TV Antenna—The TV antenna must be cranked down to its traveling position.

LP Gas Bottles—LP gas bottles and connections should be secured.

Note: *Some states prohibit vehicles equipped with LP gas bottles from using tunnels. A few other states prohibit traveling with the Service Valve open and the pilots lit. Check the regulations of the state through which you intend to travel.*

Rock Guard Awning—The unit awning should be lowered and secured (Figure 2, Page 53). To lower the awning, loosen the wing nuts and slide the awning down. Pull the retaining pins and seat in the latch hole. To raise

the awning, pull the retaining pins out and slide the awning up. Tighten the wing nuts to secure the awning at the desired height.

Safety Chains and Breakaway Switch Activator Cable—Make sure that the safety chains and breakaway switch activator cable are properly attached to the tow vehicle.

Jack Foot/Dolly Wheel (Travel Trailer)—Raise the jacks as far as possible. Remove the dolly wheel/jack foot and store in your tow vehicle trunk or in a secure place in the RV unit.

Jack Foot (Fifth Wheel)—Raise the jack as far as possible. Remove the adjusting pin from each jack. Raise the adjusting leg as far as possible and reinsert the pin.

Stabilizing Jacks—Complete retract and store jacks in their self storage area.

Automotive System—Be sure to check your tow vehicle as outlined in the tow vehicle manufacturer's owner's manual.

Interior Doors and Drawers—Close and secure all interior doors and drawers in your unit. Store or secure all loose items.

Refrigerator Door—Secure the refrigerator door with the travel latch.

Exterior Access Doors—Exterior access doors for storage and equipment should be closed and locked.

Appendix B ✓ Travel Preparation Checklist

CLOTHING

- Underwear
- Socks
- Shoes, sandals, boots
- Shirts
- Blouses
- Trousers
- Slacks
- Dresses
- Shorts
- Sweaters
- Jackets
- Coats
- Rainwear
- Swim wear
- Pajamas

TOOL CHEST

- Screwdrivers
- Pliers
- Hammers
- Tire pressure gauge
- Small level
- Electrical tape
- Masking tape
- Wrenches
- Allen wrench
- Furnace duct tape

CAMPSITE COMFORT

- Dishwashing soap
- Dishcloths
- Dishtowels
- Garbage/trash bags
- Mop
- Broom
- Vacuum cleaner
- Dust pan
- Paper towels
- Foil or plastic wrap
- Throw rug

SAFETY

- First-aid kit
- Flares
- Reflectors
- Tow rope and/or chain

ADDITIONAL TOOLS

- Hatchet
- Shovel
- Saw
- 12-volt portable tire pump

SLEEPING GEAR

- Sheets
- Pillow cases
- Mattress pads
- Blankets
- Pillows
- Sleeping bags

PERSONAL COMFORT

- Towels
- Washcloths
- Toilet paper
- Soap
- Toothbrush
- Toothpaste
- Personal toiletries
- Scissors
- Sewing kit
- Ash trays

MEAL PREPARATION

- Bottle opener
- Can opener
- Matches
- Pots, pans, skillets
- Plates
- Glasses and cups
- Silverware
- Hot pads
- Knives, spatula, etc.
- Baking pans
- Coffee maker
- Toaster
- Plastic containers

ENTERTAINMENT

- Books/magazines
- Binoculars/telescope
- Camera, film, flash
- Tape player/tapes
- Toys/games
- Playing cards
- Television
- Radio

MISC. EQUIPMENT

- Bucket
- Fuses
- Fresh water hose
- Y-type water hose fitting
- Flashlight
- 20-ft. 3-prong power cord
- 3-prong adapter with ground-ing wire
- Wheel chocks, leveling ramp, blocks or jack stands
- Coat hangers
- Folding lawn chairs

Appendix C ✓ Travel Trailer/Fifth Wheel Brakes

HOW YOUR BRAKES WORK

The brake basically is the same as your automobile brake. The major difference is the automobile uses hydraulic pressure to expand the brake shoes. Your unit brake uses an electric circuit.

When the electrical circuit is complete, high capacity electromagnets are energized and attracted to the armature surface on the brake drum. As the drum rotates, the electromagnets move the magnet lever arm in the same direction. This movement causes the actuating block to push the primary brake shoe against the drum. The force of the primary shoe pushes the secondary brake shoe in contact with the drum.

Be sure to read the Running Gear Service Manual for more detailed information.

BRAKE SYNCHRONIZATION

The best brake system is only as good as the way you use it. Your tow vehicle's brakes are designed to stop in a safe, effective manner just as your unit brakes are designed. Neither will replace the other. When one does the stopping for both, the overload causes heat. This increases the wear of the brake linings. The overload also will cause brake fade (a direct loss of brake power). Jackknifing can occur if the tow vehicle's brakes are used alone (allowing the unit to push the tow vehicle).

Proper brake synchronization is obtained when the unit brakes have a slight lead over the tow vehicle's brakes. This is done by turning the controller adjustment to decrease or increase the application rate of the unit's brakes. After this adjustment, there should be no sensation of the unit pushing the vehicle. Also, there should not be an excessive sensation of the unit pulling the vehicle when you come to a stop.

BRAKE ADJUSTMENT

To maintain the safe, reliable stopping power of your brake system, the brakes should be serviced at regular intervals or, if performance dictates, more frequently. To adjust the brakes:

1. Jack the unit up until the wheel rotates freely.
2. Secure the unit with jackstands.
3. Locate the adjusting slot in the backing plate and remove the protective plate.
4. With a standard adjusting tool or screwdriver, rotate the star wheel until the brake drag makes it difficult for the wheel to turn.
5. The star wheel now must be turned the opposite direction to allow the wheel to turn freely 3/4 to 1 revolution when spun.
6. Replace the protective plug.
7. Repeat the procedure for the other wheels.
8. Lower unit.

Note: Brakes on new units may require repeated brake applications during the first 25 miles of travel to "burnish" the lining material. The burnish process assures a proper match between lining material and drum surface. It also allows the magnet to set itself to the armature plate. These brake burnish applications should be made at 1/2 to 1 mile intervals while traveling at 20 to 30 mph without overheating the brake system. Overheating occurs when brakes begin to fade. **DO NOT** burn-in your brakes by "dragging" them!

Appendix D ✓ Troubleshooting Guide

NOTE: Use the manufacturers' owner's manuals for all appliance trouble shooting.

PROBLEM	CAUSE	SOLUTION
---------	-------	----------

ELECTRICAL POWER

No electrical power to unit.	Shoreline connection.	Make sure you have power to the shoreline.
	Circuit breaker (120V) switches may be off or tripped.	Reset breaker(s). at power center.
	Fuse (12V) may be blown.	Replace fuse at battery compartment.

POWER CONVERTER

Converter makes a clicking noise.	Circuit overload.	Reduce load on circuit.
	Reversed polarity at battery.	Correct polarity at battery.
	Short in recharge line.	Locate and fix short.

ELECTRICALLY CHARGED (HOT) CHASSIS

Chassis is electrically charged.	Short in 110/120 volt circuit.	Disconnect unit from electrical supply. Have unit inspected and repaired if necessary, by a qualified service facility. <i>NOTE: Determine if shoreline has proper polarity.</i>
	Power cord ground not connected to earth ground.	Make sure shoreline post ground is earth ground and power cord ground is used.
	Bad adapter plug.	Replace power cord adapter.

LIGHTS

Lights flickering.	Loose fuse holders.	Tighten or replace fuse holder.
	Blown fuse.	Replace fuse with one of the same ampere rating.
	Broken connection or wire.	Replace connection and/or wire.
	Bad ground.	Make sure ground connection is secure.
	Converter overheating.	Reduce loads and let converter cool down.
Lights dim or half bright.	Bad battery.	Check battery condition.
	Possible converter malfunction.	Have converter checked by an authorized service center.
	Possible low voltage from shoreline.	Make sure voltage to shoreline is not too low.

NOTE: Use the manufacturers' owner's manuals for all appliance trouble shooting.

PROBLEM	CAUSE	SOLUTION
----------------	--------------	-----------------

OUTSIDE RECEPTACLE

No power to outside receptacle.	GFI receptacle may be off or tripped.	Reset GFI at receptacle.
	Circuit breaker may be off or tripped.	Reset breaker.
	Bad power source.	Make sure you have power to the shoreline.

RV BATTERY

RV battery boiling.	Water low in battery.	Replace water to correct level in battery.
	Bad battery.	Replace battery.
	Defective battery charger in Power Center.	Have Power Center battery charger checked by an authorized service center.

RUNNING LIGHTS

No running lights.	Blown fuse.	Replace fuse with one of the same ampere rating.
	Bad bulbs.	Replace bulbs.

LP GAS

Smell gas in and/or around unit.	Possible gas leak in system.	<ol style="list-style-type: none">1. Extinguish any open flames, pilot lights and all smoking materials.2. Do not touch electrical switches.3. Shut off the gas supply at the tank valve(s) or gas supply connection.4. Open doors and other ventilating openings.5. Leave the area until odor clears.6. Have the gas system checked and leakage source corrected before using again.
----------------------------------	------------------------------	--

NOTE: Use the manufacturers' owner's manuals for all appliance trouble shooting.

PROBLEM	CAUSE	SOLUTION
WATER PUMP		
Pump fails to start when the switch is on.	Fuse located in the converter may have blown.	Replace fuse with one of the same ampere rating.
	System hooked up to city water.	Disconnect hose from city water. Do not need to run pump with city water.
Pump continues to operate whether the faucets are open or closed.	Water tank may be empty or there might be a leak in the system.	Fill water tank and/or fix any leaks in the system.
Pump goes ON and OFF with faucets shut OFF.	There may be a leak in plumbing system fittings or lines.	Fix any leaks in plumbing system, by checking all fittings for tightness and replacing any broken parts.
WASTE TANK		
Waste tank will not drain.	Build-up in tank.	Check for build-up in tank at stool. Make sure stool holds water.
TERMINATION VALVE		
Termination valve leaks.	Debris blocking valve or build-up.	Clear debris from and around valve.
	Bad gasket.	Replace gasket.
MICROWAVE OVEN		
Microwave oven will not operate.	No power to oven.	Check power supply and circuit breaker.
	Door open, or timer OFF.	Close door and turn timer ON.
FURNACE		
Furnace does not light.	May be out of LP gas.	Check the LP gas supply.
	Low battery or bad battery.	Replace water to correct level in battery, recharge battery and/or replace battery.
Furnace fan does not run.	Blown fuse.	Replace fuse with one of the same ampere rating.
The furnace does not light after several attempts. 		<ol style="list-style-type: none">1. Turn the thermostat and the furnace gas control valve OFF.2. Contact your Coachmen dealer or authorized service center. DO NOT attempt to repair or adjust the furnace yourself.

NOTE: Use the manufacturers' owner's manuals for all appliance trouble shooting.

PROBLEM	CAUSE	SOLUTION
----------------	--------------	-----------------

REFRIGERATOR

Refrigerator will not cool.

Unit not level.

Make sure unit is level.

Upper and/or lower refrigerator vents clogged.

Clear vents of all debris.

If on gas, empty tank.

Fill LP gas tank.

Blown fuse (12V).

Replace fuse with one of the same ampere rating.

TV ANTENNA

TV antenna has poor reception.

Power jack not turned on.

Turn power jack switch on.

Bad connections at TV or wall plate.

Make sure the connections are good at both TV and wall plate.

Cut or nicked cable.

Replace bad cable where needed at TV and antenna.

Antenna not pointed in direction of "sending" station.

Point antenna in direction of "sending" station.

TOWING

Unit will not tow level.

Ball hitch too low and/or high on tow vehicle.

Have it checked by an authorized dealer for a possible cure.

Too much of the load is in the back or front of RV.

Redistribute cargo to achieve the correct hitch weight.

Load leveling stabilizer bars on hitch, improperly adjusted.

Adjust stabilizer bars to the proper setting.

Note: Refer to (Pages 9 to 15) of this manual.

Travel Record

DATE	PLACE	ODOMETER READING		TOTAL MILES	NOTES	EXPENSES
		BEFORE	ARRIVAL			

Maintenance Record

DATE	MILEAGE	SERVICE SHOP NAME & ADDRESS	DESCRIPTION OF SERVICE

Maintenance Schedule*

ITEM	Every Trip	Every 30 days or 1,000 miles	Every 60 days	Every 90 days or 2,500 miles	Every 6 months or 5,000 miles	Annually or 10,000 miles	REFERENCE
Airing	•						Air Quality, Condensation, Maintenance, this manual
Appliances	•					•	Appliances, this manual; Appliance Manufacturer's instructions
Awning Supports						•	Maintenance, this manual
Axle & Suspension	•		•				Maintenance, this manual
Batteries	•	•					Maintenance, this manual
Brakes					•	•	Maintenance, this manual; Brake Manufacturer's manual
Body					•		Maintenance, this manual
Bumpers						•	Maintenance, this manual
Counter, Table Tops	•						Maintenance, this manual
Doors				•			Maintenance, this manual
Electrical System	•						Maintenance, this manual
Fabrics						•	Care of Fabrics, this manual
Floor Coverings	•						Maintenance, this manual
Frame						•	Maintenance, this manual
Hinges						•	Maintenance, this manual
Hitch Ball/Pin	•			•			Maintenance, this manual
Jacks	•			•			Maintenance, this manual; Jack Manufacturer's manual
Locks & Latches						•	Maintenance, this manual; Lock/Latch Manufacturer's manual
LP Gas	•	•					LP Gas; this manual; Appliance Manufacturer's instructions
Lug Nuts	•						Maintenance, this manual
Pigtail Contacts							Maintenance, this manual; Pigtail Manufacturer's manual
Roof, Body, Underbelly				•			Maintenance, this manual
Safety Chains	•						Maintenance, this manual
Seams (Seal)						•	Maintenance, this manual
Shades, Valances	•						Maintenance, this manual
Steps	•					•	Maintenance, this manual; Step Manufacturer's instructions
Tires	•					•	Pre-Travel Check, Maintenance, this manual; Tire Manufacturer's manual
TV Antenna		•					TV Antenna Manufacturer's instructions
Vents						•	Maintenance, this manual; Vent Manufacturer's instructions
Vinyl Ceiling & Wall Panels	•						Maintenance, this manual
Water Heater	•					•	Maintenance, this manual; Water Heater Manufacturer's manual
Wheel Bearings						•	Maintenance, this manual; Axle Manufacturer's instructions
Windows	•						Maintenance, this manual; Window Manufacturer's instructions
Wood Cabinetry	•		•				Maintenance, this manual

* Maintenance schedules listed are minimum requirements; heavy use, unusual temperatures or humidity, or other environmental conditions may require more frequent maintenance.

Appliance Identification Form

Should your unit or one of the appliances require warranty service, you will have to identify the manufacturer, model designator and serial number. Fill in this form as soon as possible. It will help you meet identification requirement. Depending on your unit, certain items listed below may be offered as either optional and/or standard. Most of this information can be found on the Recreational Vehicle Data and Quality Assurance Information sticker attached to the inside of one of the kitchen cabinets.

EQUIPMENT	MANUFACTURER	MODEL DESIGNATOR	SERIAL NUMBER
Travel Trailer or Fifth Wheel	_____	_____	_____
Converter/Power Center	_____	_____	_____
Water Pump	_____	_____	_____
Furnace	_____	_____	_____
Generator	_____	_____	_____
Keys—Door	_____	_____	_____
Exterior Storage	_____	_____	_____
Other	_____	_____	_____
Microwave Oven	_____	_____	_____
Radio/Cassette Player	_____	_____	_____
Range/Oven	_____	_____	_____
Refrigerator	_____	_____	_____
Washer	_____	_____	_____
Dryer	_____	_____	_____
Roof Air Conditioner(s)	_____	_____	_____
Toilet	_____	_____	_____
TV	_____	_____	_____
TV Antenna	_____	_____	_____
Water Heater	_____	_____	_____

ELECTRICAL SPECIFICATIONS

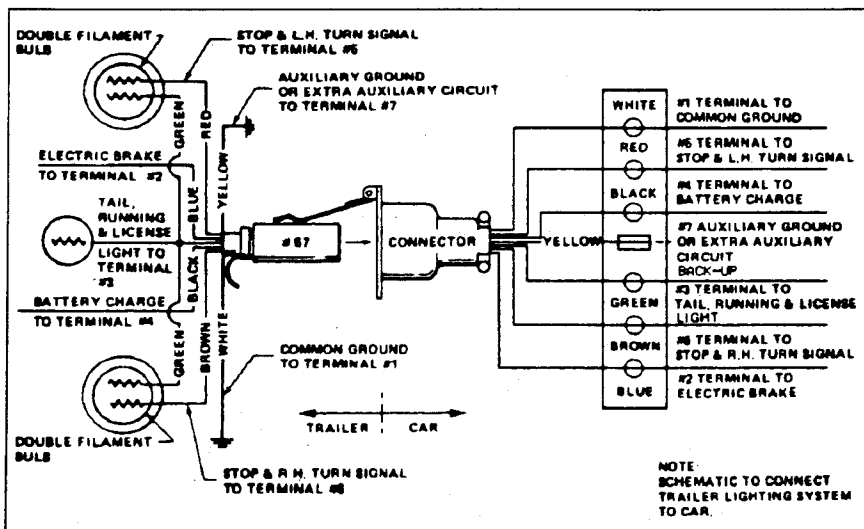

PIGTAIL WIRING DIAGRAM

COLOR CODE FOR PIGTAIL

- WhiteCommon to Ground
- RedStop & Left Turn
- BrownStop & Right Turn
- GreenTail, Running & License Plate
- BlueElectric Brake
- YellowBackup
- BlackConverter/Interior

LIGHT BULBS

- Interior 12-volt DC#1141
- Range Hood25 W, 12-VDC
- Turn, Tail & Stop#1157
- Backup#1156
- License Plate#67
- Clearance, Grab Handle#67
- Patio#93
- Water Pump Fuse15 AMP, Slo Blo

MISCELLANEOUS

See the brochure for the exterior dimensions, capacities, weight ratings and wheel/tire ratings which pertain to your unit.

Reporting Safety Defects

If you believe that your vehicle has a defect which could cause a crash or could cause injury or death, you should immediately inform the National Highway Traffic Safety Administration (NHTSA) in addition to notifying COACHMEN RECREATIONAL VEHICLE COMPANY.

If NHTSA receives similar complaints, it may open an investigation, and if it finds that a safety defect exists in a group of vehicles, it may order a recall and remedy campaign. However, NHTSA cannot become involved in individual problems between you, your dealer, or COACHMEN RECREATIONAL VEHICLE COMPANY.

To contact NHTSA, you may either call the Auto Safety Hotline toll-free at 1-800-424-9393 (or 366-0123 in Washington, D.C. area) or write to: NHTSA, U.S. Department of Transportation, Washington, D.C. 20590. You can also obtain other information about motor vehicle safety from the Hotline.

Travel Notes



Coachmen Industries, Inc. was founded in Middlebury, Indiana, in 1964 by Claude, Keith and Tom Corson. The three brothers recognized business opportunities in the new and growing recreational vehicle (RV) industry and tried to combine their business experience in finance, marketing and manufacturing.

Their confidence in the RV industry was well founded. From first-year production that included 12 travel trailers, one pick-up truck camper and 80 truck

caps, the Company has become a diversified, full-line manufacturer of recreational vehicles under many well-known brand names with well over 449,000 units manufactured. The Company's RV product line includes travel trailers, fifth wheel trailers, motorhomes, truck campers, camping trailers and van conversions.

The Coachmen RV complex includes 120 acres with 588,000 square feet of assembly facilities under roof.



Coachmen[®]

RECREATIONAL VEHICLE CO.

P.O. Box 1000
Middlebury, Indiana 46540

The Coachmen recreational vehicles described in this manual incorporate components produced by Coachmen Industries, its divisions, and various other suppliers. During the product year, Coachmen may decide to produce units with different components and/or specifications than initially scheduled. All such

changes are approved for use by Coachmen in order to maintain the quality standards associated with the Coachmen name. All illustrations and specifications contained in this owners manual are based on the latest product information at time of publication. Coachmen reserves the right to make changes in operations, materials, equipment and specifications at any time without notice. Coachmen assumes no responsibility for any error in type or print reproduction of specifications in this owners manual. Check with your Coachmen dealer for more information if you have specific questions.